

Southwest Windpower, Inc.
Renewable Energy Made Simple

Owners Manual
Installation, Operation and Maintenance



WHISPER WIND GENERATORS
MODEL Whisper 100
For the *NEW* Whisper Controller



Southwest Windpower, Inc.
1801 West Route 66
Flagstaff, Arizona 86001
Phone: (928)-779-9463
Fax: (928)-779-1485

Email: info@windenergy.com
Web page: <http://www.windenergy.com>

© January 2005 Southwest Windpower, Inc
All Right Reserved

WIND GENERATOR SERIAL NUMBER _____

Southwest Windpower, Inc.

Renewable Energy Made Simple

Owners Manual

Installation, Operation and Maintenance



WHISPER WIND GENERATORS
MODEL Whisper 100
For the *NEW* Whisper Controller

Southwest Windpower, Inc.
1801 West Route 66
Flagstaff, Arizona 86001
Phone: (928)-779-9463
Fax: (928)-779-1485

Email: info@windenergy.com
Web page: <http://www.windenergy.com>

© January 2005 Southwest Windpower , Inc
All Right Reserved

WIND GENERATOR SERIAL NUMBER _____

Table of Contents

Introduction	
1. Tower Installation	7
2. Battery Selection	7
3. Battery Configuration and Location	8
4. Setting Wind Turbine Voltage	9
5. Wind Turbine Electrical Tests	11
6. Mounting Wind Turbine On Tower	12
7. Whisper Controller - Mounting	13
8. Whisper Controller - Wiring	14
9. Whisper Controller - PCB Switches and Reset Button	16
10. Optional Display Installation	18
11. Tail Installation	19
12. Blade and Nose Cone Installation	20
13. Operation of Whisper Controller	21
14. Maintenance - Monthly	26
15. Maintenance - Annual	27
16. Troubleshooting and Repair	29
17. Mechanical Repair and Replacement	34

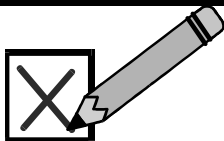

FOLLOW STEP-BY-STEP INSTALLATION

LOOK FOR THE SHADED BOXES AND FOLLOW THE STEPS IN ORDER. CHECK THE PROVIDED BOX WHEN COMPLETE.

SUGGESTED TOOLS AND EQUIPMENT YOU WILL NEED

Round or Half Round File	Pliers
10mm or 3/8" Metal Cutting Drill Bit	Metric wrenches and sockets
Torque Wrench (20 Nm / 15 ft-lb)	Large Adjustable Wrench
Blue Loctite 242	Electrical tape
Sawhorse	Hex Wrenches Set (metric)
Electrical Wire (see p. 6)	Ground Rod and Clamp
Electric Drill Motor	Soldering Iron and Solder

WELCOME TO YOUR RENEWABLE ENERGY SYSTEM!

ELECTRICITY FROM THE WIND AND SUN:

Renewable electric power systems provide independent (no utility grid!) electric power for boats, homeowners, farms, villages and commercial applications such as telecommunications. If utility power is available, your renewable energy system can reduce the electric bill and with a battery system provide back up electricity during storms or line failure. The most common sources of renewable electric power in these systems are small wind powered generators and solar photovoltaic (PV) modules that convert sunlight directly to electricity. Renewable means power sources that do not deplete the world's finite fossil fuel resources, do not pollute or warm the atmosphere and do not generate hazardous waste. Electricity means your children can study at night for a better future and you can benefit from appliances, power tools and communication technologies that make life easier and more rewarding. Nearly three billion people in the world do not have electricity and by necessity most will ultimately get their electricity from renewable resources to the benefit of everybody. You are a pioneer and part of the solution!

BEFORE YOU BEGIN:

Read this entire manual. Identify and note your model wind generator where it appears in this manual. Following the instructions and recommendations in this manual will help assure safe and enjoyable use of your new renewable energy system.

SAFETY INFORMATION: These systems present mechanical, electrical and chemical (battery) hazards that can be life threatening. The tower or support structure could fall and cause injury or death and property destruction. A component of the wind generator could come loose causing injury or death and property destruction. Contact with the high speed propeller can result in severe injury or death. High voltage from the wind generator or the inverter can cause injury or electrocution. A severe chemical burn including blinding can occur from a battery explosion or contact with the sulfuric acid in a lead-acid battery.

These conditions are addressed in the following safety messages:

STOP! DANGER! It is your responsibility to obtain all required permits and engineering certifications for your tower and tower location. Soil and wind conditions vary and towers and tower foundations must be designed for your specific location. Tower must not be able to fall on occupied buildings, neighbor's property or power lines. Tower climbing is dangerous and should be attempted only by experienced personnel using proper safety equipment. A fold-over tower can eliminate climbing. Locate your mounting mast (tower) well away from occupied buildings and power lines; a minimum of 100m (300 ft) is recommended.

STOP! DANGER! If the generator appears or sounds loose in the tower or is making an unusual sound, the condition must be corrected immediately. A loose generator or component will soon damage itself further and may fall from the tower or lose parts that could be lethal. Never stand in line with a spinning propeller.

STOP! DANGER! Provide climbing protection against all unauthorized persons or children. Never allow an untrained person or someone without the proper safety equipment to climb the tower. Always stop the propeller before climbing the tower. Both falling from the tower and contact with the spinning propeller can be lethal.

STOP! DANGER! High voltage systems (that is, systems with battery voltages of 64 volts and above or the primary side of any system with a transformer) represent a dangerous shock hazard and could be lethal. All high voltage systems should be wired and maintained by a qualified and licensed electrician.

STOP! DANGER! Batteries may emit explosive and irritating gas while charging. Never turn on a light switch or make any other electrical connection or light a match or make any type of spark near a recently-charged battery. Use protective gloves and eyeglasses when working around a battery. Turn off all loads, wear safety glasses, and look away when making a final battery connection.

STOP! DANGER! NEVER place objects on top or near the Whisper-Controller enclosure. These devices must dissipate heat as part of normal operation. FAILURE AND FIRE may result if airflow is blocked.

DESCRIPTION OF SYSTEMS

The illustration below depicts a typical installation. For more information regarding specifications of wind, wind/solar and inverter systems, contact Southwest Windpower. Note that the illustration below is for information purposes only. See the appropriate section to properly wire your own wind system.

Whisper Wind Generators include the Whisper Controller System Center and the user supplies the battery, tower, inverter and wiring. During windless periods, solar panels may supplement your usage of renewable energy. Solar PV (photovoltaic) panels make electricity directly from sunlight. Batteries store electricity so you have power during windless and sunless periods as well as periods of high demand. A deep cycle type of battery must be used. If you have the wind generator only, use this manual to help size the battery and inverter.

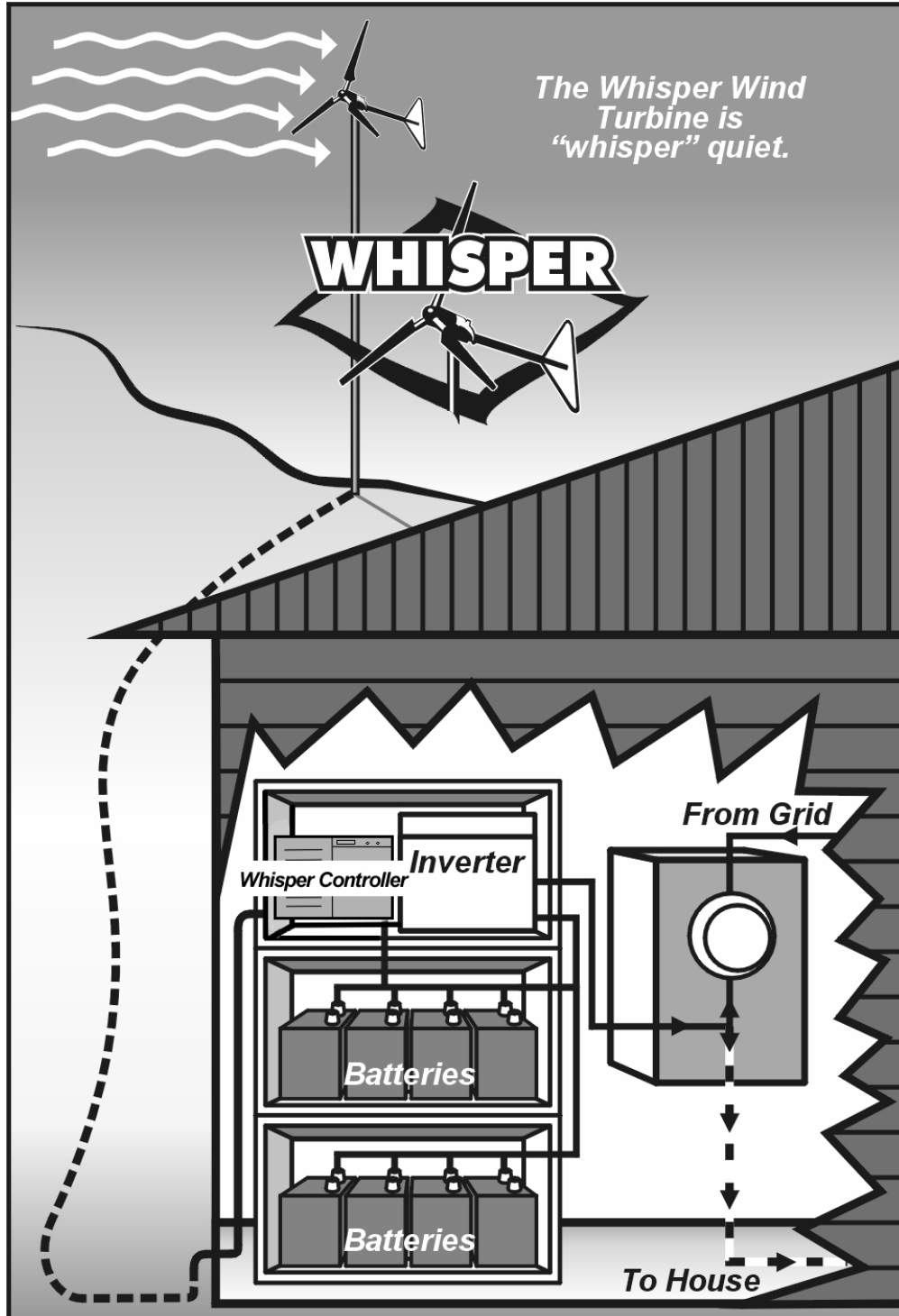

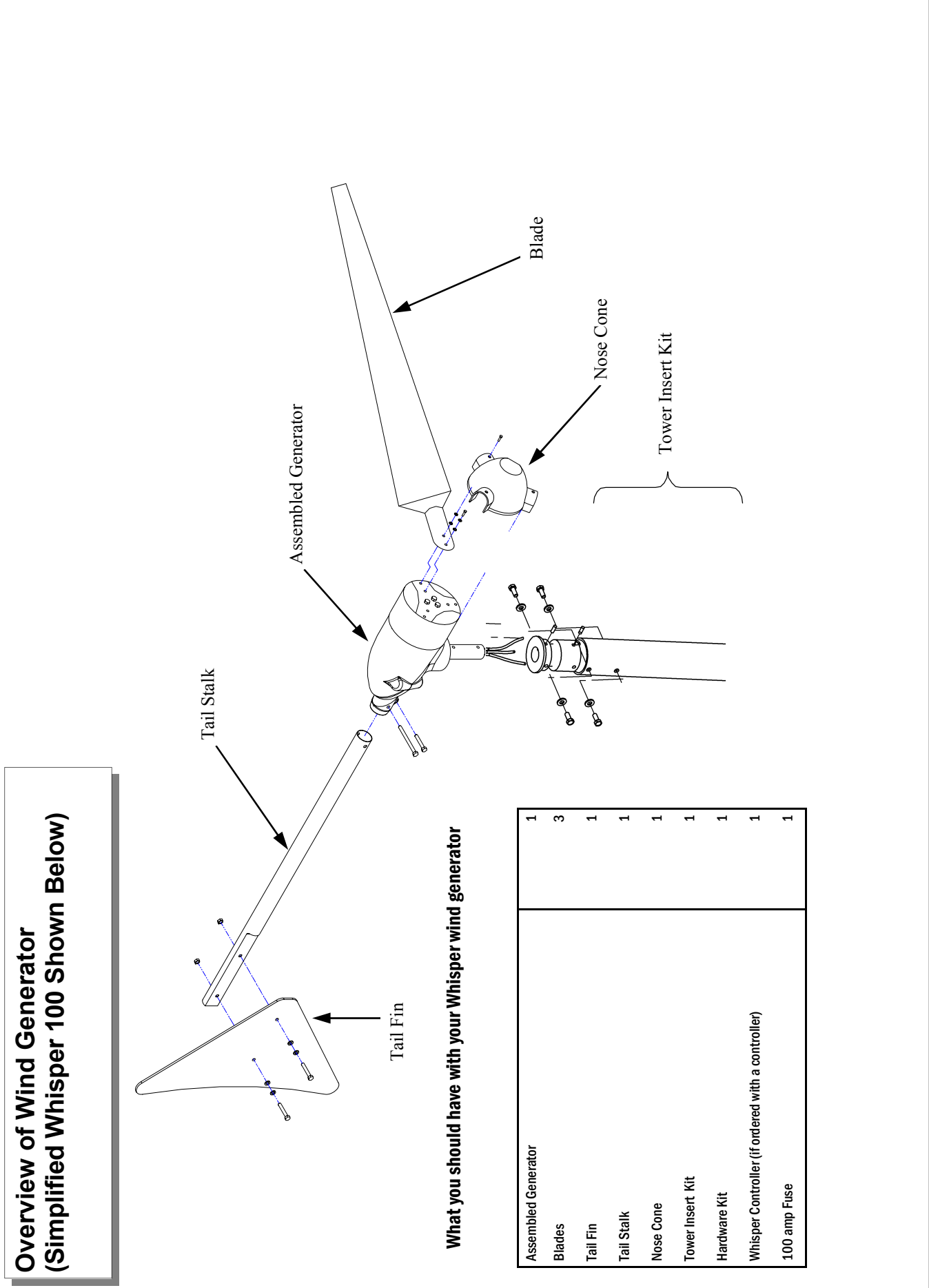

Typical Renewable Energy System Wiring

You will need to make the electrical connections as shown below.

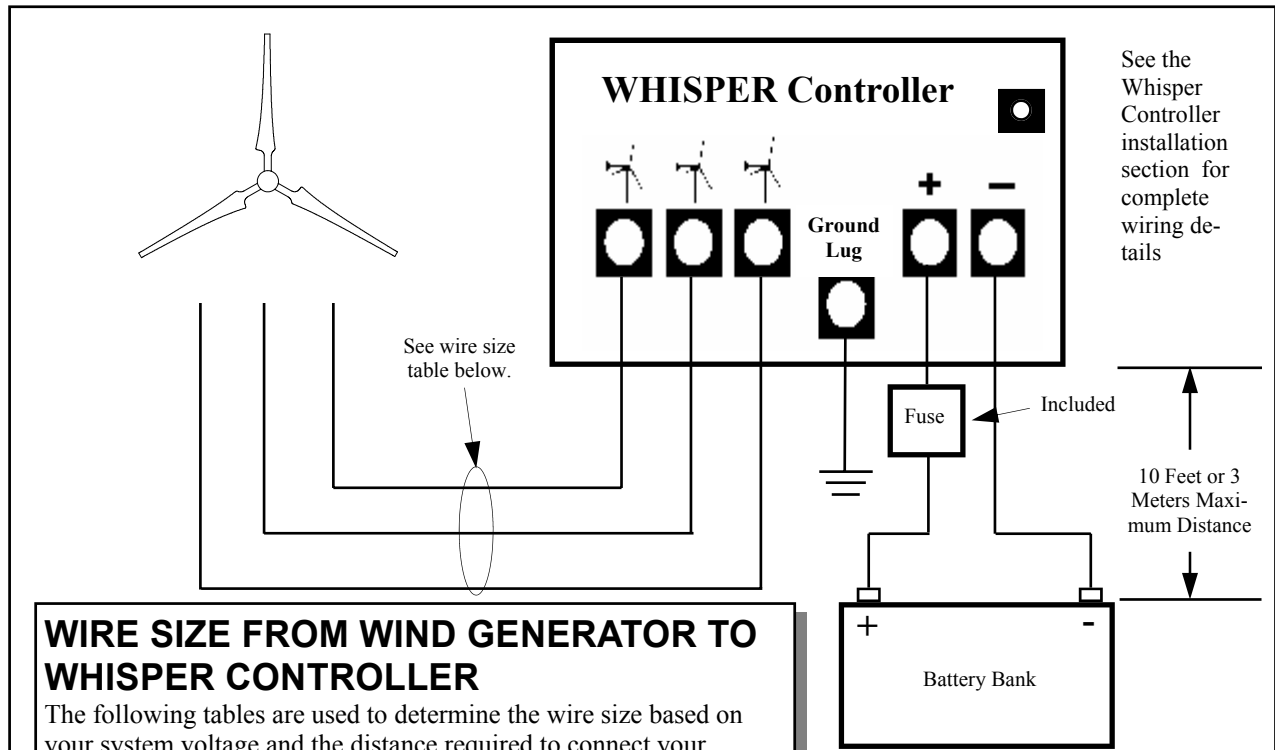

WIRE SIZE FROM WIND GENERATOR TO WHISPER CONTROLLER

The following tables are used to determine the wire size based on your system voltage and the distance required to connect your Whisper 100 to the WHISPER Controller. Distances are one way from the turbine connection to Whisper Controller terminals.

* See Whisper Controller—Wiring section for instructions on wiring battery to Whisper Controller.

VOLTS	12	24	36	48
COPPER WIRE SIZE	FEET			
AWG 12	xx	xx	108	216
10	xx	xx	173	346
8	xx	138	276	552
6	xx	218	436	872
4	84	339	678	1356
3	136	542	1084	2168
2	170	682	1364	2728
1	216	860	1720	3440
0	274	1098	2195	4390
2/0	342	1364	2727	5454
3/0	434	1730	3462	6924
4/0	546	2177	4355	8710

VOLTS	12	24	30-36	48
COPPER WIRE SIZE	METERS			
AWG 12	xx	xx	xx	66
10	xx	xx	53	106
8	xx	42	84	168
6	xx	66	133	266
4	26	103	207	414
3	42	165	330	660
2	52	208	416	832
1	66	262	524	1048
0	82	335	669	1338
2/0	104	416	831	1662
3/0	132	528	1055	2110
4/0	166	664	1327	2654

*If using aluminum wire, multiply the distances in the table by 0.65.

Inch to Metric Conversion — AWG

AWG SIZE	14	12	10	8	6	4	3	2	1	0	2/0	3/0
Diam inches	0.064	0.081	0.102	0.129	0.162	0.204	0.229	0.258	0.289	0.325	0.365	0.409
Diam mm	1.628	2.057	2.591	3.277	4.115	5.182	5.817	6.553	7.341	8.255	9.271	10.389

1. Tower Installation

1. TOWER LOCATION/TYPE AND HEIGHT. INSTALL TOWER

(Install tower following manufacturer's instructions.)

Tower height minimum is 7 meters (20 feet) above trees or obstacles within 100m (300ft). The highest point on your property is generally best, but wind generator distance to battery and the battery voltage determine the correct wire size (Refer to wire size table pg. 6). A self supporting tower occupies less ground area than a guyed tower but is more expensive. A tilt-up design permits easy installation and maintenance on the ground and eliminates the need for climbing.

The Whisper 100 is suitable for side-of-building mounting on **unoccupied** buildings such as garage or barn. Some vibration transmission will be noticeable from mounts to structure. Foundations must be designed and approved for local wind/soil conditions.

Consult with a professional engineer to determine proper type and location of tower installation.

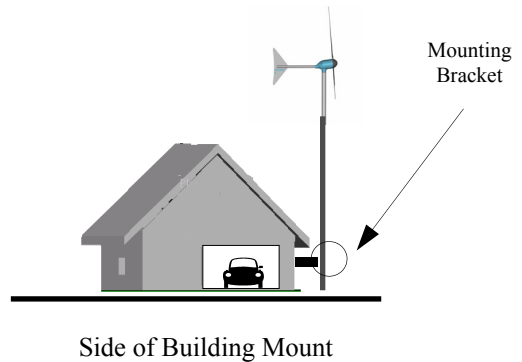
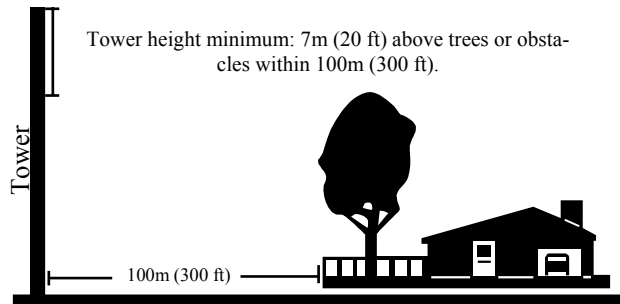

2. Battery Selection

See Table below for minimum battery size.

MINIMUM BATTERY SIZES

Wind Generator Model	Whisper 100
Battery System Volts	12, 24, 36, 48
Minimum Amp x Hours (20 hour rate)	200
Minimum Kilowatt Hours (Volts x Amps x Hours/1000)	4

3. Battery Configuration and Location

Locate battery in moderately stable room temperature, dry unoccupied building. Battery performance is optimal at room temperatures. Run AC power from inverter to house or load. If battery is in an occupied building, an enclosure with vent to outside is required. Follow code. See the following diagrams for package system series/parallel arrangement.

Determine series/parallel arrangement and construct a rack or mount from heavy, treated lumber, or other suitable material. Allow 5 cm (2 in) on all sides for ventilation. Allow 60 cm (2 ft) vertical clearance for access to terminals and checking water.

Coat all connections with grease or corrosion protector available at auto parts store. Install **Whisper Controller** and Inverter fuse (if used) at battery positive. To minimize the possibility of EMI (electromagnetic interference), the line from the battery to the **Whisper Controller** should be less than 10 feet (3 meters).

Recommended Battery Fuse Installation (Consult local electrical codes)

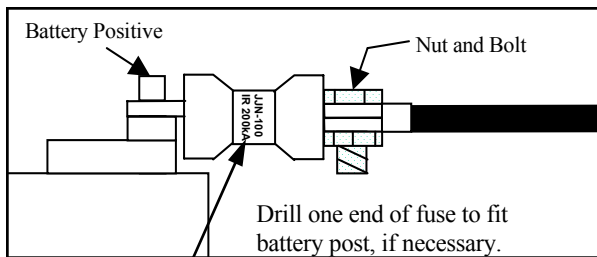

Fuse Included

Use the diagrams below to determine the series/parallel arrangement for your system voltage (typical 6 volt battery arrangement shown).

12 Volt Configuration

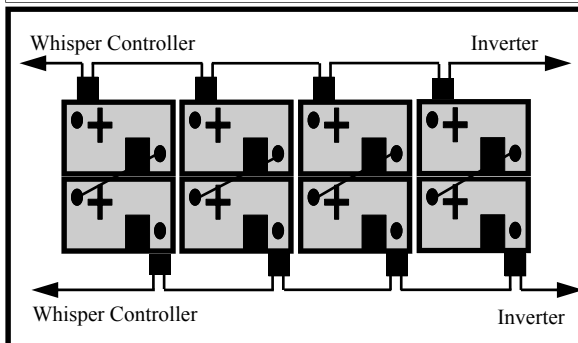

24 Volt Configuration

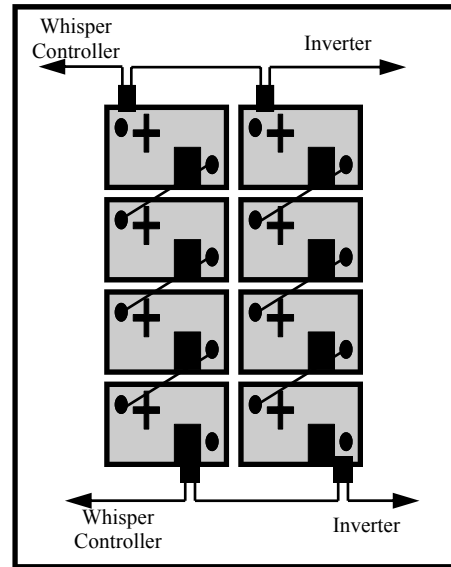

48 Volt Configuration

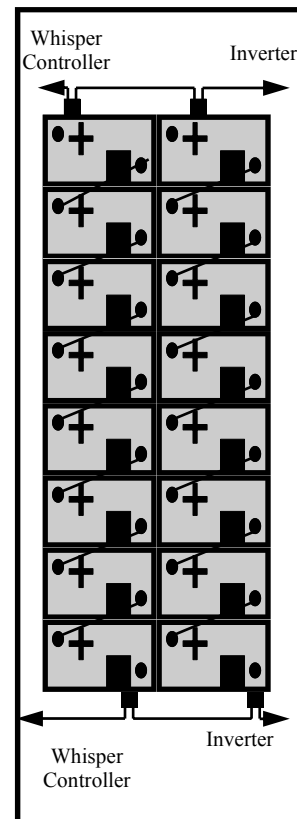

4. Setting Wind Turbine Voltage

Introduction

The Whisper 100 Wind Generator and Controller must be configured for the correct system voltage - 12, 24, 36 or 48 volts. Whisper Wind Generators and Controllers are shipped from the factory configured for 24 volt operation unless specially ordered.

To check the Wind Generator voltage configuration or to change the voltage, refer to the following notes and wiring table. Your Whisper Dealer may also be of assistance configuring your Wind Generator to the voltage for your application if different from 24 volts.

To check the Controller voltage setting or to change the voltage setting, refer to Sections 8, 9 and 10 for instructions.

Wiring and Assembly Notes

The correct Whisper 100 voltage is set by altering the 12 stator wire and 3 brush wire connections. The wire connections are made using appropriate size wire nut connectors.

To access the wires remove the metal "Multi Voltage" cover on the side of the Whisper turbine housing. Refer to the following Voltage Configuration Wiring Table for specific stator and brush wire connections.

Observe the following notes when changing the voltage configuration:

- The three brush wires are interchangeable and are not labeled. The brush wires are easily identifiable as they are larger multi-strand wires and stator wires are solid wire. (8 awg compared to 20 awg).
- Stator wires are numbered and color coded with a wire sleeve. For example stator wire "Red 3" has a red sleeve with the number "3" printed on it. Wire "Red -" has a red sleeve with no number. The "-" indicates there is no number. There is a "Red -", "White -", and "Black -" stator wire.
- When changing the voltage configuration cut off the twisted ends of the wires (stator wires only) and strip off approximately 25mm (1 inch) of insulation.

Important Note:

In addition to the PVC insulation, the stator wires are also coated with varnish that **MUST** be removed to make a good connection. The varnish can be removed by scraping with sharp edge or lightly sandpapering the wire.

- Hold the stripped ends of the wires to be joined parallel to each other and twist together with pliers before installing the wire nut. The wires should be twisted in a clockwise direction.
- Cut of the "untwisted" ends of the wires and twist on the appropriate color wire nut. Push hard on the wire nut while twisting clockwise.
- Coat wire nuts and terminal strip connections with dielectric grease to protect wires against corrosion. A tube of dielectric grease is supplied with each Whisper 100.

Voltage Configuration Wiring Table

Reference the following table to determine the correct brush and stator wire connections for your voltage configuration. Note the correct color (size) wire nut is indicated for each connection.

WHISPER 100/200 MULTI-VOLTAGE WIRING				
	Red Wire Nuts			
	BRUSH WIRE	BRUSH WIRE	BRUSH WIRE	
12V	WHITE 1	WHITE -	RED 1	
	WHITE 3	WHITE 2	RED 3	
	BLACK 2	RED 2	BLACK 1	
	BLACK -	RED -	BLACK 3	
	Red Wire Nuts			Yellow Wire Nuts
	BRUSH WIRE	BRUSH WIRE	BRUSH WIRE	WHITE -
24V	WHITE 1	RED 2	BLACK 1	WHITE 2
	WHITE 3	RED -	BLACK 3	RED 1
	Red Wire Nuts			BLACK 2
	Red Wire Nuts			Yellow Wire Nuts
	BRUSH WIRE	BRUSH WIRE	BRUSH WIRE	WHITE 2
48V	WHITE 1	RED -	BLACK 1	RED 2
				WHITE 3
				RED 1
				BLACK -
				RED 3
				BLACK 2
				BLACK 3

5. Wind Turbine Electrical Tests

Complete these tests before mounting blades to rotor.
These tests confirm that the wind generator was not damaged in shipment and is ready to install on the tower.

GROUND TEST



Check resistance to ground on any wire. Resistance must exceed 10,000 ohms.

OPEN CIRCUIT TEST

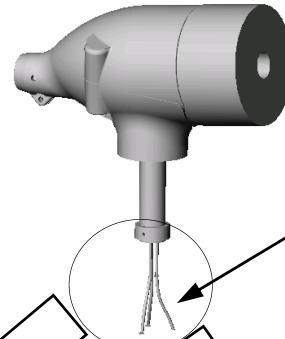

When the wires are unconnected the wind generator rotor should spin freely.

When all the wires are shorted together the generator rotor should turn hard and smooth.

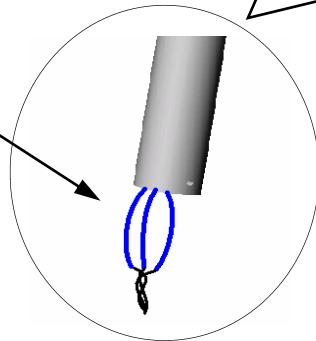

SHORT CIRCUIT TEST

When any two wires are shorted together the generator rotor should turn lumpy as though there are smooth and bumpy portions of the rotor

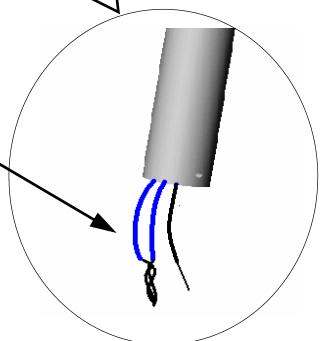

PHASE TO PHASE TEST

6. Mounting Wind Turbine On Tower

Mounting Instructions

Check fit of insert by placing it inside the tower. A maximum of 1.5 mm (1/16 in) play is allowed. You must be able to pull pipe or tube tight against insert with mounting bolts. Next, using the template supplied on the last page of this manual, drill holes in the tower tube. Check to see that the holes in the tower line up with the threaded holes in the insert. Install insert on yaw shaft with slot facing down. The slot is used for tower cable grip strain relief. Use medium-strength thread locking compound on all fasteners. M6 X 20 Allen head set-screws must engage both engagement holes in yaw shaft.

Solder or use split bolts to make electrical connections. **A good wire connection is crucial.** Any wind generator wire can go to any tower wire. Wrap connections thoroughly with electrical tape to prevent shorts to tower. Support wires to avoid weight on slip ring wires and wire connections. Slide generator without propeller into tower and install mounting hardware as shown. Make sure the top flange of the tower insert is resting on the top end of the tower pipe. Insert and torque all four insert mounting bolts (M8 x 35mm) to 10-11 ft-lb. (12-14 N-m) repeating any tightening sequence used at least four times. As an option, the tower tube may be insulated with pipe insulation to prevent the wires from rattling.

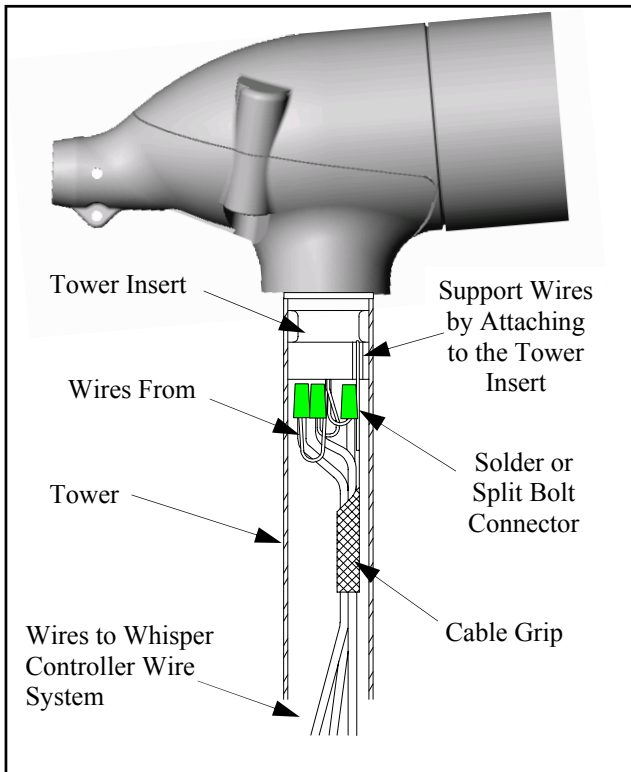

Tower Insert Kit

For 2.5 Schedule 40 Pipe (2.875 O.D. x .20Wall)

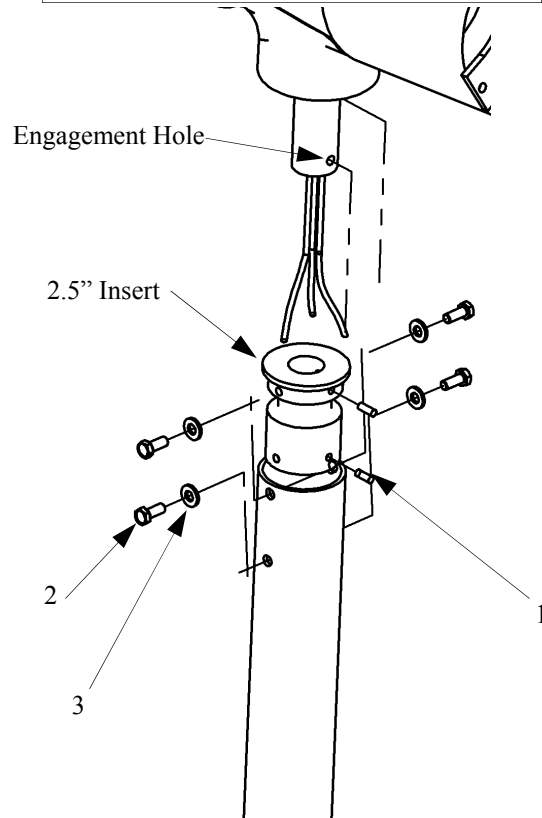

Item	Description	Quantity
1	Set Screw (M6 X 20)	2
2	Bolt M8 X 35	4
3	M8 SS Nylock Nut	4

7. Whisper Controller - Mounting

PRELIMINARY CONTROLLER MOUNTING INSTRUCTIONS

Please note that for preliminary turbine to controller tests, it may be convenient to temporarily mount the Whisper Controller close to Wind Turbine. This will allow the user easy access to the controls and displays while testing the turbine and controller functionality. The tests should be performed prior to mounting the blades.

Mounting

The Whisper Controller must be mounted vertically against a wall with the LEDs and Diversion Switch to the top. Vertical mounting is required to provide good heat convection for the resistor bank (dump load). Since the dump load side of the controller may get very hot, do not mount the unit near anything flammable or heat sensitive.

Conduit knockouts on the bottom of the controller unit accommodate 0.75", 1.25", and 1.5" nominal size conduit. An earth ground connection terminal is provided inside the controller between the turbine and battery mounting blocks.

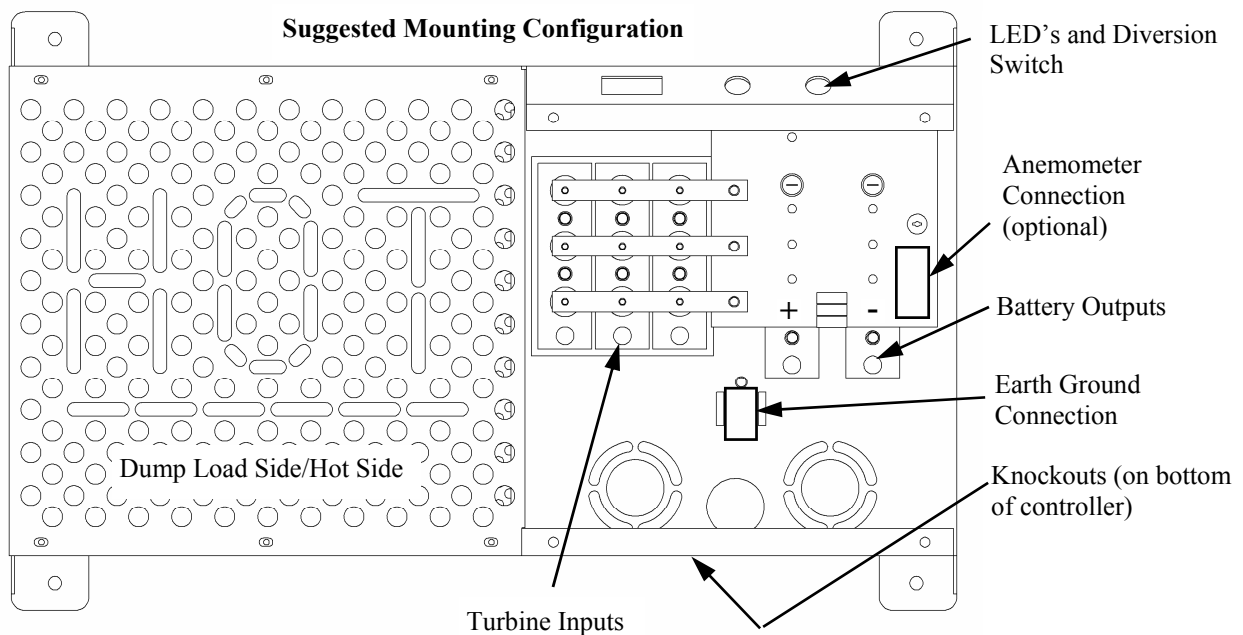

8. Whisper Controller - Wiring

Important Notice

The Whisper Controller is factory preset for 24-volt operation. If your system is other than 24 volts the Controller **MUST** be configured for your system voltage.

Both the Whisper Controller resistive “dump” load and the controller printed circuit board (PCB) **MUST** be configured for the system voltage. Refer to the following sections for specific directions.

Connecting

Remove the Whisper Controller Electronic Cover and connect the battery, wind turbine and ground wires as shown in the accompanying schematic. **Caution: Southwest Windpower recommends connecting the Controller to the batteries BEFORE making the wind turbine connections.** Use caution when connecting the battery leads to avoid shorting them together.

First connect the battery to the controller and check the microprocessor is energized correctly by switching the Diversion Switch to the “Stop” position. The red LED should illuminate. If not, momentarily depress the “Reset” switch on the controller printed circuit board (see following section on the Printed Circuit Board).

Return the diversion switch to the battery position and observe the red LED to turn off. When connecting the battery try not to allow the connection to “bounce” causing the microprocessor to power up and then power down quickly. This kind of quick on-off cycle can cause the microprocessor to latch up. If the microprocessor locks up and depressing the Reset button does not correct the problem contact Southwest Windpower for instructions.

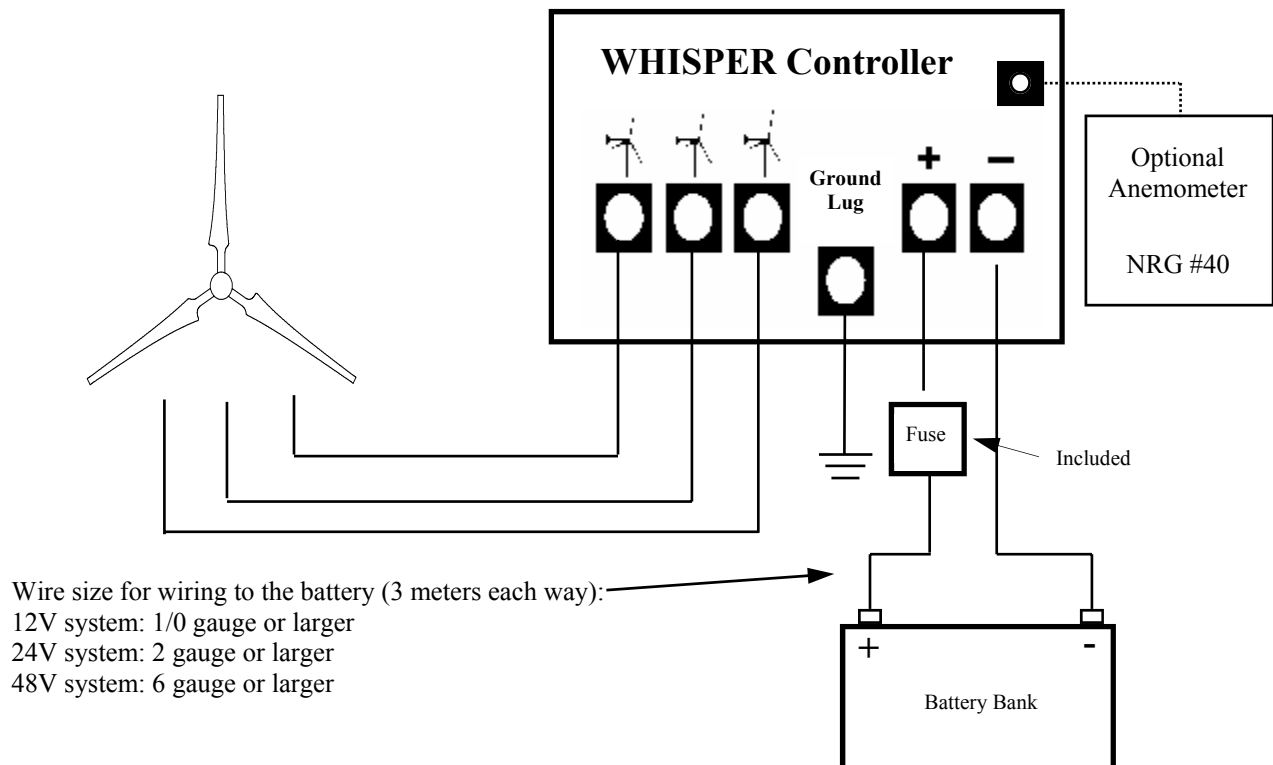

Once startup is successful and the red LED can be cycled by toggling the Diversion Switch, then set the switch to “Stop” (Red LED on) and connect the turbine wires to the controller (order of the turbine wires is not important). With the Red LED is on, the turbine will not spin as long as at least two of its wires are connected. For further operational information refer to Whisper Controller Operation on page 22.

Dump Load Wiring

Refer to the figures below and wire the resistive “dump” load for your system voltage. Sufficient jumper wires are provided with the Whisper Controller such that any 12, 24, 36 and 48 volt configuration can be accomplished.

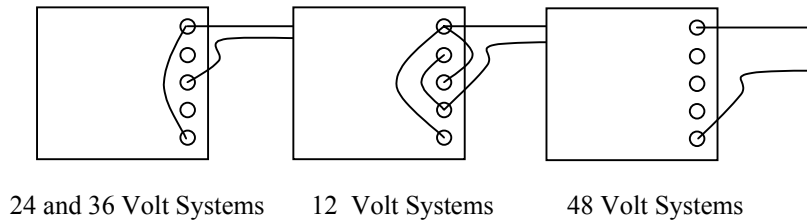

Optional Anemometer Connection

The Whisper Controller has been designed to accommodate a Model #40 anemometer, manufactured by NRG. Other equivalent anemometers may work, compare manufacturers specifications.

A terminal block on the circuit board is the connection point for the two anemometer signal wires. The terminal block connections are labeled +/-, the polarity should be observed since some anemometers require specific polarity connections. A ground shield (if applicable) should be connected to the controller’s grounding terminal.

To achieve the most meaningful air speed data the anemometer should be mounted on the turbine tower as near as possible to the turbine without entering the turbine’s sphere of operation. See the manufacturer’s recommended installation instructions.



9. Whisper Controller - Printed Circuit Board Switches and Reset Button

Introduction

The Whisper Controller Printed Circuit Board is equipped with six switches that are used to set certain operating system parameters. The default switch settings are suitable for the majority of installations and should not be changed with the exception of two switches that **MUST** be changed to alter the system voltage. Instructions for changing the system voltage are given below.

The printed circuit board is also equipped with a “Reset” switch that is used to reset the microprocessor. Depressing the switch has the same effect as disconnecting a battery cable from the Whisper Controller.

Note that if voltage regulation points are set using the Optional Display they will be lost if the Reset Switch is depressed or a battery cable is disconnected. In this case the controller will revert to the potentiometer set points. Refer to sections on Reset Switch, Adjusting the System Voltage and Optional Display for additional information.

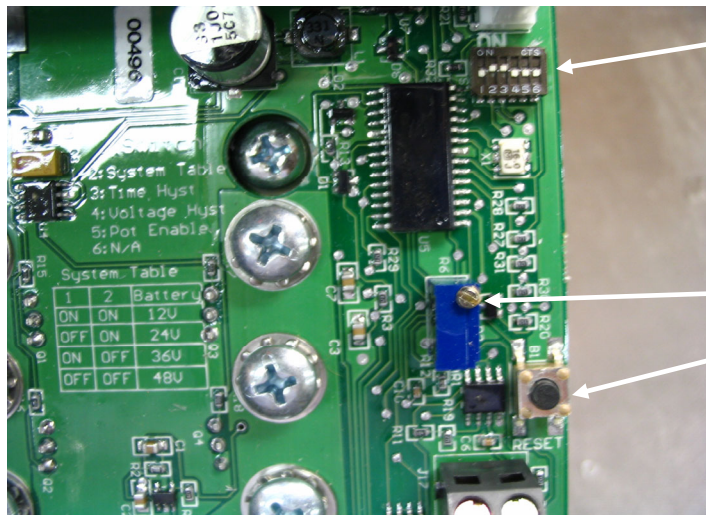

Default Switch Settings
for 24 Volt Operation

1. OFF
2. ON
3. ON
4. OFF
5. OFF
6. OFF

Potentiometer

Reset Switch

Printed Circuit Board Switch Settings

Switches 1 and 2, System Voltage

Select the correct system voltage by setting the position of Switches 1 and 2 according to the following table.

System Voltage	Switch 1	Switch 2
12 Volt	ON	ON
24 Volt	OFF	ON
36 Volt	ON	OFF
48 Volt	OFF	OFF

After changing the system voltage depress the Reset switch to “read and save” the new voltage setting.

Switch 3, Time Hysteresis, Default Setting “ON”

With Switch 3 set to “ON” the Whisper Controller implements a 30-40 second time delay for both the voltage on and off regulation set points. For example the Whisper Controller continue charging the batteries for 30-40 seconds after the voltage regulation-on set point is achieved and will not resume charging until 30-40 seconds after the regulation-off set point is achieved.

Switch Settings (continued)

Switch 3. Time Hysteresis (continued)

With Switch 3 set to "OFF" the Whisper will start and stop charging the batteries immediately at the voltage regulation set points. It is not necessary to depress the Reset Switch after changing the switch setting.

Except in VERY special circumstances Southwest Windpower recommends Switch 3 remain in the "ON" position.

Switch 4. Voltage Hysteresis, Default Setting "OFF"

With Switch 4 set to "OFF" the Whisper Controller will start and stop charging the batteries at the voltage regulation set points established either through the Optional Display or by the printed circuit board potentiometer.

With Switch 4 set to "ON" the voltage regulation-on point (the point battery charging stops) set using the potentiometer will be increased by 1.0 volts for 12 volt system, 2.0 volts for 24 volt systems, 3.0 volts for 36 volts systems and 4.0 volts for 48 volt systems. The voltage regulation-off set point (the point battery charging resumes) is unaffected by setting the switch to "ON".

The Voltage Hysteresis Switch does not increase the regulation-on and off set points set using the Optional Display. In other words it is not additive with the Optional Display set points. It is not necessary to depress the Reset Switch after changing the switch setting.

Switch 5. Potentiometer Enable, Default Setting "OFF"

Switch 5 in the "ON" position enables reading the potentiometer voltage on the Optional Display in real time. The resolution limits of the display are 0.2, 0.4 and 0.8 volts for 12, 24 and 48 volt systems respectively.

With the Switch set to "ON", voltage regulation points may not be set using the Optional Display. They must be set using the potentiometer.

With the Switch set to "OFF" prevents changing the voltage regulation set point by the potentiometer. It is not necessary to depress the Reset Switch after changing the switch setting.

Switch 6. Default Setting "OFF"

There is no function presently associated with this switch. It is recommended to leave the switch in the "OFF" position.

Whisper Controller Reset Switch

Operation of the Whisper Controller is controlled by a microprocessor and software contained on the Whisper Controller printed circuit board. A reset switch is provided as means to restart the microprocessor and operating control software without needing to disconnect battery power.

To reset the microprocessor momentarily press the reset button. The location of the button is depicted on the previous page. If it is necessary to depress the switch a second time allow approximately 15 seconds before depressing the switch a second time.

Note that if custom voltage regulation on and off voltage regulation points are set using the optional display, these settings will be lost when the reset switch is depressed and the Whisper Controller reverts to the potentiometer voltage setting. The values are also lost if the battery is disconnected.

Whisper Controller Components

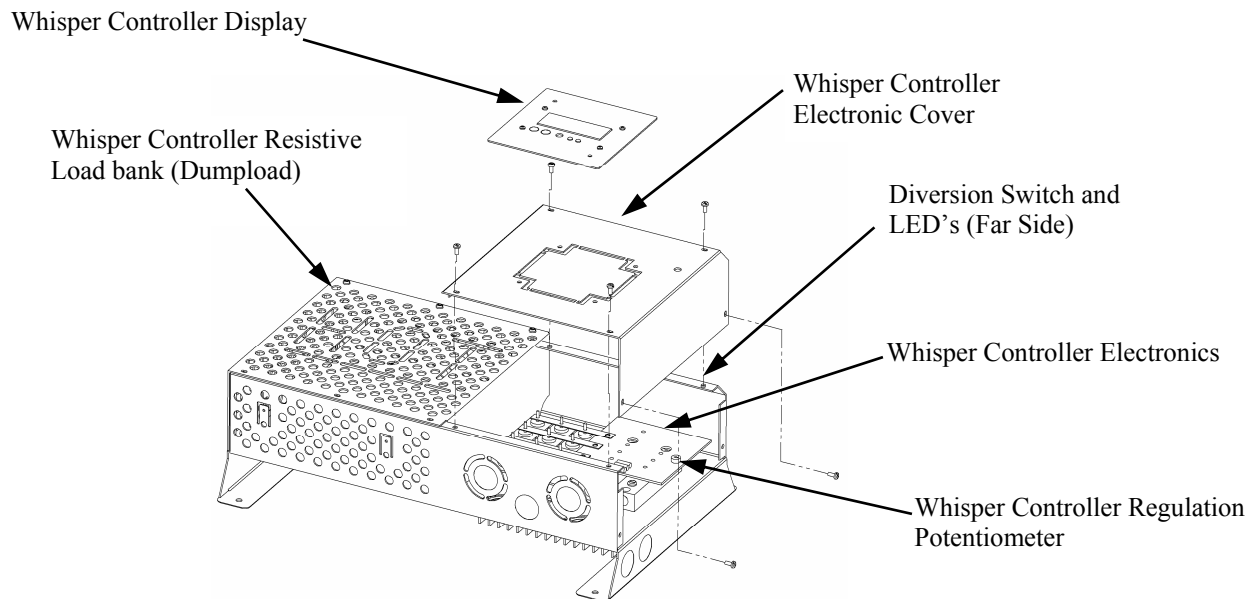

10. Optional Display Installation

The optional display was designed to be mounted either on the Whisper Controller base unit, or in a wall type switch receptacle. Hardware is provided with the display. There is a short ethernet CAT5 cable provided for Controller base installation.

Local Display Installation

If the display is to be mounted directly on the Whisper Controller you will need to remove the electronics cover and knock out the sheet metal insert where the display will mount. There are pre-drilled holes to mount the display. Use the provided 8-32 x 3/8", black oxide, stainless steel screws, and 8-32 nuts with captive star washers to mount the display to the electronics cover.

Connect the display cable to the CAT5 jack located nearest the diversion switch. This will indicate to the display that it is locally mounted and it will disable its LED features, since these are redundant to those mounted on the Whisper Controller base. Leave the cover off until the display function is verified.

Remote Display Installation

The display may be located in a remote location (up to 300 meters / 1000 feet) away from the Whisper Controller. Use Category 5 ethernet cable will have to be purchased. Install the display in the desired location and connect the ethernet cable to the display unit.

Remove the electronics cover on the Whisper Controller. If necessary, knock out one of the sheet metal plugs in the Whisper Controller base unit and route the ethernet cable inside the unit. Plug the ethernet cable into the jack in the lower right corner of the controller board. Leave the cover off until the display function is verified.

Display Function Verification

Once the display is plugged into the controller base and the batteries are connected to the controller there should be text displayed on the LCD display. If the display is blank there is a contrast adjusting potentiometer that can be adjusted to brighten the display. Insert a bladed screwdriver into the hole on the display between the buttons and the LEDs. Turn the potentiometer to adjust the brightness. If a display is still not visible disconnect and reconnect the cable to the display to reset the display. Once display function is verified re-install the electronics cover on the controller base.

The system wiring is now complete. Proceed to assembling the turbine and mounting blades to rotor.



11. Tail Installation

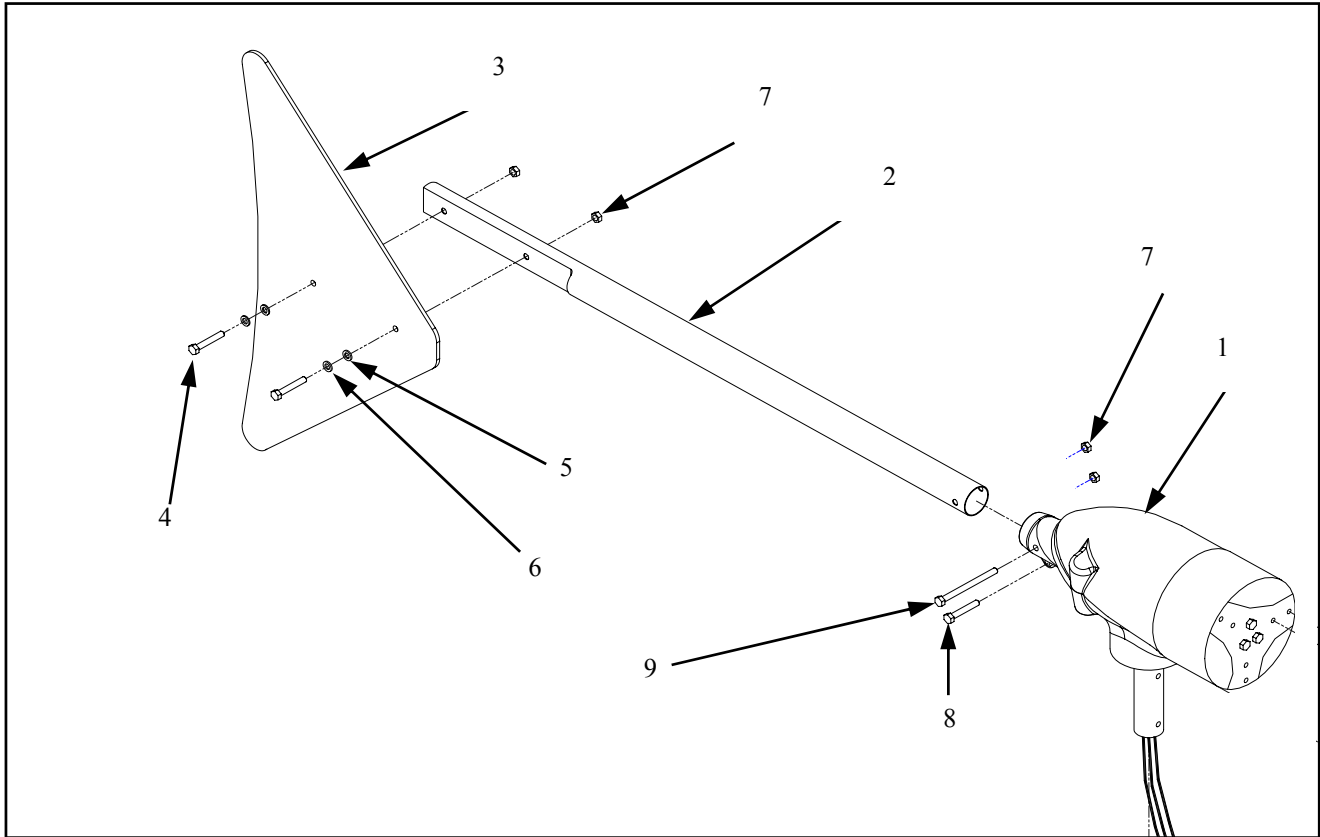

Item Number	Description	Quantity
1	Assembled Generator	1
2	Tail Stalk	1
3	Tail Fin	1
4	Hex Bolts, M8 x 55	2
5	Nylon Washer, M8 X 31	2
6	SSTL Washer, M8 x 24	2
7	Nylock Nut, M8	4
8	Hex Bolt, M8 x 25	1
9	Hex Bolt, M8 x 70	1

12. Blade and Nose Cone Installation

INSTALL BLADE AND NOSE CONE. DIVERSION SWITCH IN "STOP" POSITION.

1. Flat (ribbed) side of blade lays against rotor front plate.
2. Use thread locking compound (Loctite 242 or equivalent) on all bolts.
3. Loosely install all items except Item 2 (Nose Cone). Insure that Item 8 (blade strap) is contacting the top portion of the blade as shown below. Note # 6 bolts are slightly longer than # 4 bolts and must go in a specific location.
4. Start by installing outboard hardware 4 (Bolt, M8 x 50) , 3 (Flat Washer, M8 x 24), and 7 (Nylock Nut, M8). Install Items 4 (Bolt, M8 x 50) and 5 (Lock Washer, M8) on innermost rotor bolt circle. This inner bolt circle will be covered by Item 2 (Nose Cone) in step 6.
5. Torque all Item 4 (Bolt, M8 x 50) to 8 ft/lbs (11Nm). Do not over-tighten.
6. Install Item 2 (Nose Cone) using Item 3 (Flat Washer, M8 x 24), 5 (Lock Washer, M8), and 6 (Bolt, M8 x 55).
7. Torque remaining bolts to 8 ft/lbs (11Nm).

WHISPER 100 Blade Installation

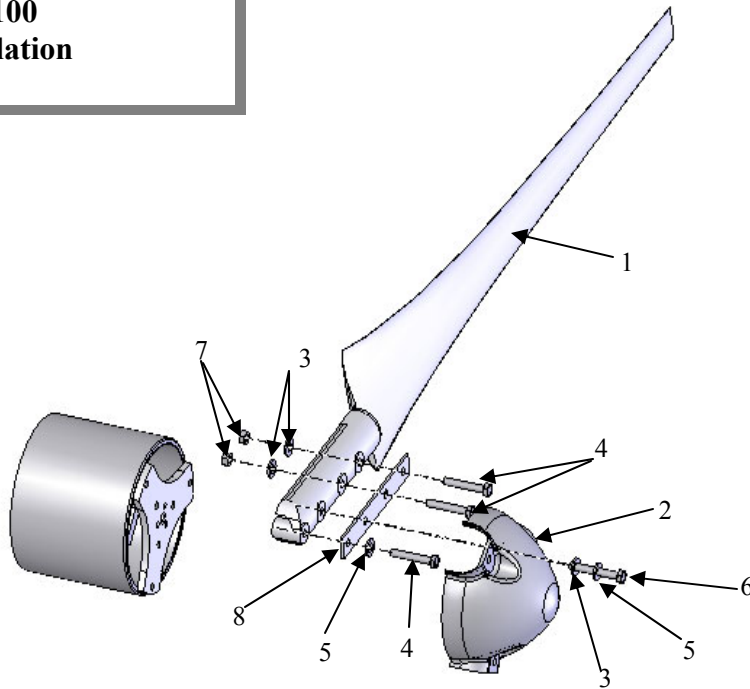

Item	Description	Quantity
1	Blade	3
2	Nose Cone	1
3	Flat Washer, M8 x 24	9
4	Hex Bolt, M8 x 50	9
5	Lock Washer, M8	6
6	Hex Bolt, M8 x 55	3
7	Nylock Nut, M8	6
8	Blade Strap	3

13. Operation of the Whisper Controller

1. Normal Operation – Whisper Controller Overview

The Whisper Controller is a one part of a two part system specifically designed to control the operation and convert the power of a Southwest Windpower Whisper 100 or 200. Its basic functions are rectification, regulation, and resistive power dumping. However, to best accommodate many individual customers, the Whisper Controller offers many features and adjustable operation parameters.

The main Whisper Controller block (hereafter the “Controller”) is a functionally autonomous unit. The Controller contains all of the Whisper turbine’s power electronics including rectification and load diversion. Additionally, it continuously monitors voltage, current, energy production, and wind speed (if equipped). These parameters are measured to ascertain system parameters (i.e. battery voltage) and turbine state (i.e. whether power is being generated).

The auxiliary Whisper Controller Display block (hereafter the “Display”) offers an interface to the many operational parameters and system measurements of which the Controller is capable. It can be mounted at the Controller or in a remote location or (with two Displays) both places. From the Display, instant and easy access is gained to voltage, current, power, energy, charge, peak power, and wind speed (with optional anemometer).

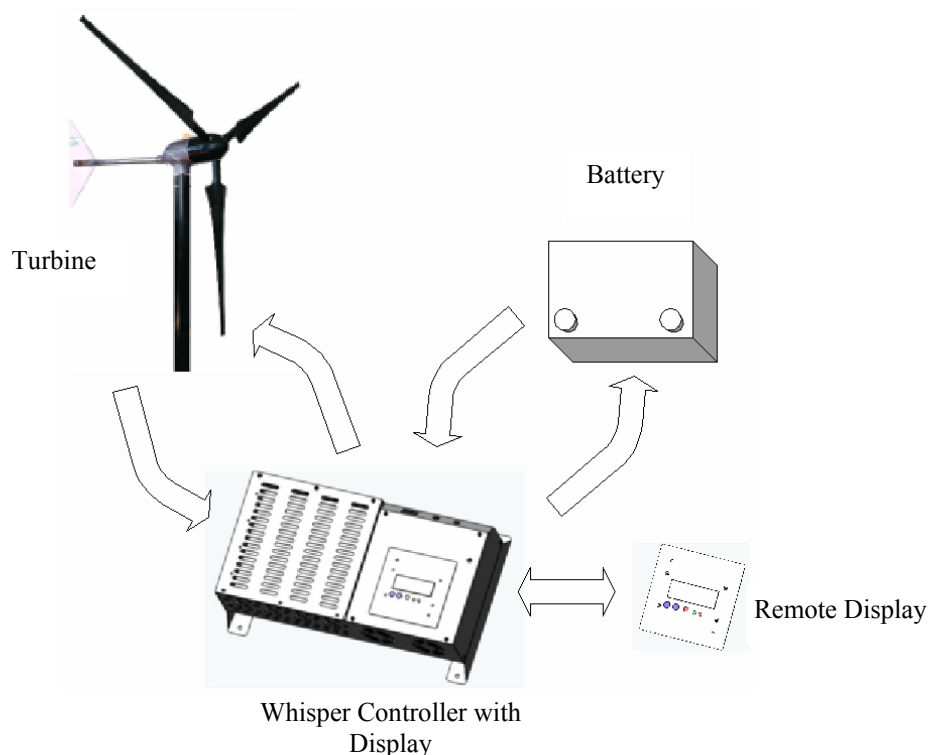

2. Normal Operation – Whisper Controller

The Whisper Controller provides all of the necessary functions and displays for safe and productive turbine operation. It includes interface features for setting the regulation voltage, monitoring the state of the system, and manually disabling battery charging. The interface mechanisms of the Whisper Controller are the LED Display, the Diversion Switch, and the Regulation Adjustment.

3. Diversion Switch

The diversion switch is located on the top of the controller to the left of the LEDs. This switch will divert turbine power to the dumpload to keep the batteries from being charged. **While this switch does not necessarily stop a spinning turbine,** once the turbine has stopped, this switch will keep it from spinning. Therefore, it should be noted that in most situations this switch can be used as a stop switch; however, spinning blades with an activated diversion switch is a normal and safe operational state.

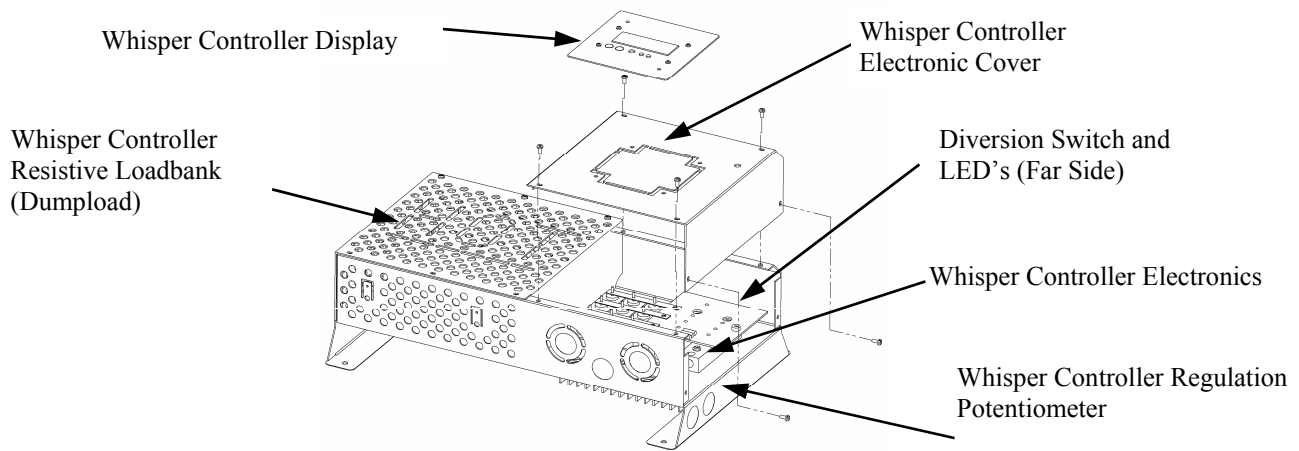

4. LED Operation

In short, the Red LED indicates that turbine power is being diverted to the dumpload and the Green LED indicates that the turbine is spinning and the battery is being charged. The LED operation is detailed in the tables below.

Red LED	Interpretation
Off	Available turbine power directed to battery.
Blinking	Available turbine power directed to dumpload for battery regulation.
On	Available turbine power directed to dumpload by operator request (via either Diversion Switch or remote Display).

Green LED	Interpretation
Off	No charge is going to the batteries; either the windspeed is too low or power is being diverted (see Red LED).
On	The batteries are being charged.

5. Setting Regulation Voltage (without Display)

The battery voltage at which the controller begins regulating the battery voltage (i.e. diverting power to the dumpload) is called the Regulation-On Voltage. This point may be adjusted by using a potentiometer on the controller’s circuit board. When the controller measures battery voltage above the Regulation-On Voltage for more than approximately 30-40 seconds, the controller begins diverting power.

The voltage at which the controller resumes charging the batteries is refer to at the Regulation-Off voltage. If the controller senses battery voltage below the Regulation-On Voltage for approximately 30-40 second will stop diverting power and start charging the battery again.

Before adjusting the regulation setpoint understand that turning up the regulation voltage will not increase the turbine’s output voltage or current. This setpoint adjusts the “regulation- on ” voltage for battery charging. Over-charging will significantly reduce a battery’s life expectancy.

Refer to the following chart for approximate potentiometer set points. Turning the potentiometer clockwise CW increases the voltage set points.

Note: Before making adjustments it is a good idea to determine the initial potentiometer position by turning the potentiometer fully CCW while counting the number of turns. Record the number of turns.

Pot Position	Regulation Off Voltage				Regulation On Voltage			
Fully CCW	12.0V	24.0v	36.0v	48.0v	13.0V	26.0v	39.0v	52.0v
4 Turns CCW	13.0V	26.0v	39.0v	52.0v	14.0V	28.0v	42.0v	56.0v
Factory Preset	13.4V	26.8v	40.2v	53.6v	14.4V	28.8v	43.2v	57.6v
9 Turns CW	14.0V	28.0v	42.0v	56.0v	15.0V	30.0v	45.0v	60.0v
13 Turns CW	14.0V	28.0v	42.0v	56.0v	16.0V	32.0v	48.0v	64.0v
Fully CW (18 turns)	14.0V	28.0v	42.0v	56.0v	17.0V	34.0v	51.0v	68.0v

6. Whisper Controller Display

Normal Operation – Whisper Controller Display

The Whisper Controller Display adds a tremendous set of features to your Whisper wind turbine system. Controller measurements can be monitored and operational parameters can be adjusted. Take the time to learn about your Whisper Controller Display to take advantage of its many features.

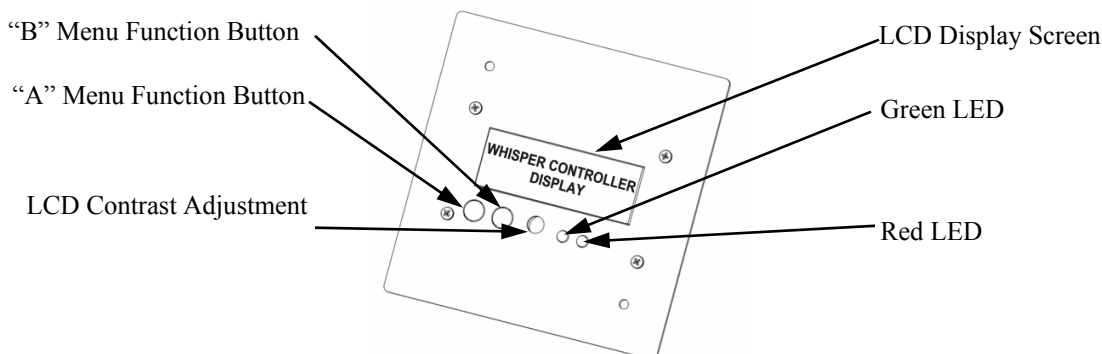

LED Display

Functionally, the Display unit's LEDs operate the same as the Controller's LEDs (see Section 13 - Operation of Whisper Controller). Due to communication lag times, there may be subtle difference in these two sets of LEDs. Therefore, it is recommended that if the Display is mounted in the lid of the Controller, that the Display be plugged into the Controller board jack in the lower right corner of the Controller board. This will automatically disable the Display's LEDs. The Controller board jack closest to the Diversion switch should be used for a remotely mounted display.

LCD Contrast Potentiometer

The contrast potentiometer can be accessed through the cover of the Display unit via a hole situated between the buttons and the LEDs. The pot is optimized at the factory for room temperature operation; however, deviations from room temperature can cause the LCD to appear too dark or too light. Carefully insert a screwdriver through the display lid and turn the potentiometer counter-clockwise to increase the darkness of the LCD.

Display Operation Overview

The basic navigational structure of the display pages are rings with the structure shown in the figure on page 20. Each of the menu pages in this main ring structure is an access point for various controller and display settings. The "A" and "B" *Function* buttons scroll between the menu pages, or change parameters on the menu, or sub-pages. The Reference Numbers in the following paragraph headings refer to menu pages shown in the table on page 19.

Main Page (1)

When first connected, the Display begins with the Main Page. The Main Page displays all of the Controller's measured parameters, including battery charging status, windspeed, charging voltage, battery charge current, and turbine power.

There are four sub-pages associated with this page. From the Main Display the "A" Function button moves through the Energy and History menu pages. From the Main Display the "B" Function button moves through the Mode and Regulation menu pages.

Energy Page (2)

Displayed on the Energy page is the accumulated kilowatt-hours and kilo amp-hours since the last reset. These can be reset from the reset sub-menu. The leftmost numbers are reset at the factory. From the Energy page the "A" menu button will go to the History page. The "B" menu button will go to the Energy Reset page.

History Page (3)

Displayed on this page are the average and peak windspeed and turbine power since the last reset. Windspeed is only available if the optional anemometer is installed. Both of these readings can be reset via the reset menu. From the History page the "A" menu button will go to the Main Display page. The "B" menu button will go to the History Reset page.

Mode Page (4)

This page displays the current charge mode. When “ON” is displayed the batteries are being charged, provided that adequate windspeed is turning the turbine. This mode allows the turbine to turn all of the time unless regulating battery voltage or disabled with the Diversion Switch or from this Mode page. When “OFF” is displayed any power being produced by the turbine is diverted to the dumpload by the controller. The “OFF” mode will brake the turbine and prevent it from turning in light winds.

The Controller can switch to “OFF” (Stop) mode in any of the following three conditions:

“OFF_REM” indicates turbine power is diverted to the dumpload due to a request from the Remote Display.

“OFF_MAN” indicates turbine power is diverted to the dumpload due to a request from the Diversion Switch being placed in the “Stop” position.

“OFF_REG” indicates turbine power is diverted to the dumpload due to automatic regulation at the prescribed voltage.

NOTE: The Diversion Switch set to “OFF” (Stop) manually overrides the Remote Display “ON” function.

The mode can be toggled using the “A” menu button. The “B” menu button will go to the Regulation Set page.

Regulation Set Page (5)

Once the Whisper Controller Display is hooked to a Controller, the Controller no longer looks to its potentiometer for setting the regulation voltage. Instead, the regulation on and off voltages are set digitally at the Regulation Page. This page displays a menu allowing change to the Regulation On and Regulation Off set voltages. Selecting “change” using the “A” menu button will bring up a sub-page allowing the Regulation On voltage to be changed. Pressing the “B” menu button will increase the voltage to a maximum of 17.0v and will then roll back to 13.0v. Pressing the “A” menu button will go to the Regulation Off voltage sub-page. Pressing the “B” menu button will again increase the voltage to a maximum of one voltage setting lower than the Regulation On voltage and will then roll back to 12.0v. Pressing the “A” menu button will return back to the Regulation Set page. Pressing the “B” menu button from this page will return to the Main Display page.

Clearly the Regulation Off voltage cannot be specified above the Regulation On voltage.

Display Menu Functions

Ref #	Page	Display			Menu Select	Effect
1	Main	On or Off		00.0 mph	“A”	go to A ring
		11.3V	00.0A	000W	”B”	go to B ring
A Ring						
2	Energy	KWh	0000	000.00	”B”	go to reset menu
		kAh	0000	000.00		
	Reset Menu	Reset kWh?	A: RESET	B: CANCEL	“A”	reset power
					”B”	return to reset menu
3	History	Mph:	00.0a	00.0p	”B”	go to reset menu
		pow:	00.0a	00.0p		
	Reset Menu	Reset Page?	A: RESET	B: CANCEL	“A”	reset readings
					”B”	return to reset menu
B Ring						
4	Mode	Mode:	On		“A”	batteries charging
		A: OFF_REM	B: SKIP		”B”	go to regulation set menu
		Mode:	Off		“A”	batteries diverted
		A: ON_REM	B: SKIP		”B”	go to regulation set menu
5	Regulation Set	REGULATION SET:			“A”	change regulation point
		A: CHANGE	B: SKIP		”B”	return to Main Menu
	Regulation On	Regulation ON voltage:			“A”	go to regulation off menu
		15.8v			”B”	Increase ON set voltage
	Regulation Off	Regulation OFF voltage:			“A”	go to regulation set menu
		12.8V			”B”	Increase OFF set voltage

14. Maintenance - Monthly

1. TEST DIVERSION CONTROL

(This checks electrical wiring.)

DIVERT THE LOAD (BY SETTING THE DIVERSION SWITCH TO "STOP") IN A MODERATE WIND (CHARGING BUT NOT FURLING). No unusual difficulty or noise should be experienced in stopping the propeller. A noise during diversion can indicate a disconnected wire.

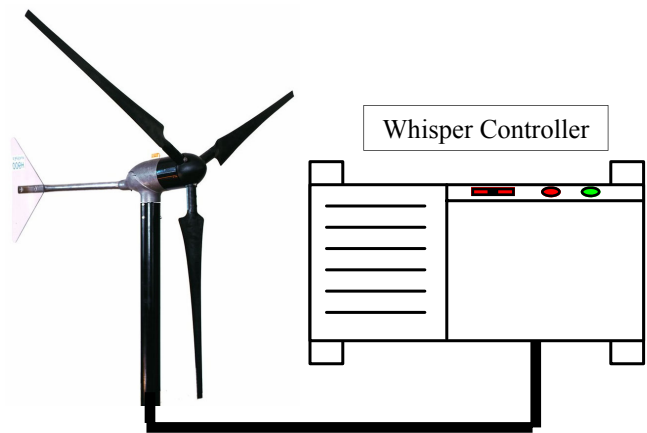

2. CHECK MECHANICAL CONDITION

WATCH AND LISTEN FROM THE TOWER BASE. Use binoculars. There should be no mechanical noise, rattle or vibration. The propeller and tail must not wobble. Lower or climb the tower for inspection, if indicated. There should be no buzzing either heard or felt with your hand on the tower mast. Go to Electrical Problems, if indicated.



3. INSPECT THE TOWER

Follow all inspection and maintenance requirements of the tower manufacturer. Tighten all nuts and bolts, especially wire clips. Check for cracks and bent or broken parts at the anchors and base structure. Check for broken strands and tighten guys.

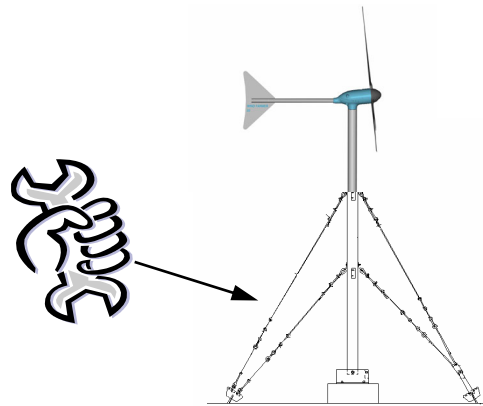

4. CHECK THE BATTERY

Add only distilled water if needed. (Consult your battery manufacturer guide.)

Tighten battery connections

Remove corrosion and protect terminals

Wipe tops with baking soda solution.



15. Maintenance - Annual

LOWER TOWER AND GIVE WIND GENERATOR A COMPLETE MECHANICAL CHECK. FIX OR REPLACE ANY WORN OR LOOSE PARTS.

- a) Check tightness of all tower mounting nuts and bolts and propeller mounting bolts.
- b) Check all bearings. Just perceptible play is acceptable.
- c) Clean the propeller with a mild detergent solution to remove all dirt and debris. Avoid scratching the surface. Replace blades if they are cracked or damaged.

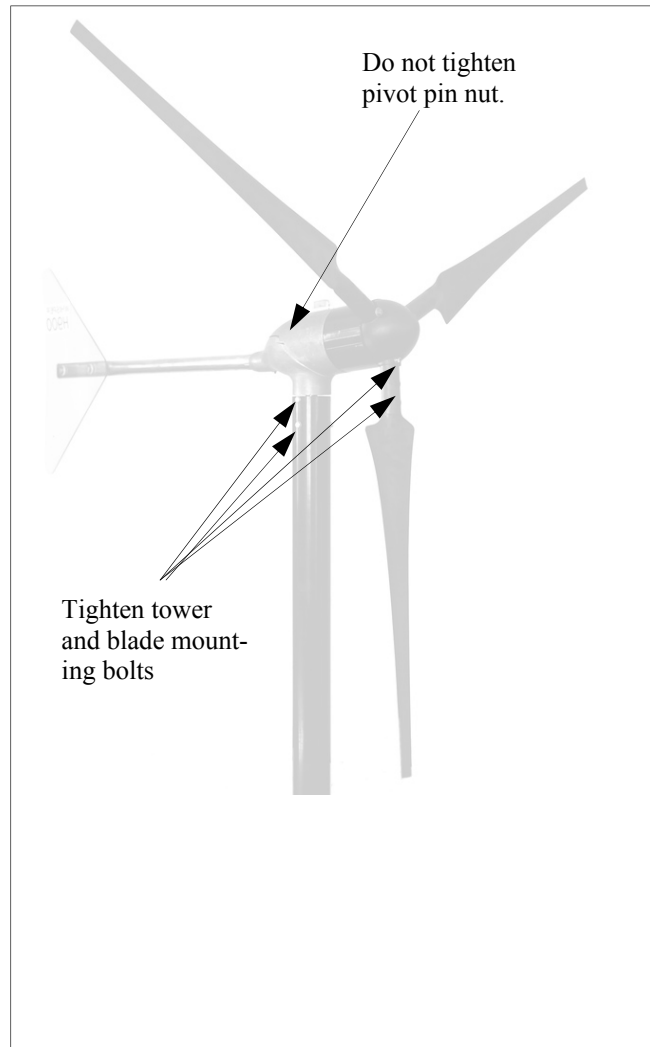

15. Troubleshooting and Repair

WIND GENERATOR SYSTEM

First, one must determine if the problem is mechanical or electrical. Refer to the two illustrations below and then proceed to the appropriate section.



**Propeller does not turn = Mechanical Problem
(Or turns slowly)**

Proceed directly to **Table: Symptoms of Mechanical Problems**

Propeller turns slowly = Electrical Problem

Proceed to **ELECTRICAL DIAGNOSIS, PAGE 31**, to diagnose the type of electrical problem the turbine is experiencing.

Table: Symptoms of Mechanical Problems

Symptom	Possible Cause	Correction
1. Propeller is stationary, even in high winds	a. Ice in generator, or ice on propeller b. Debris between rotor and stator c. Loose, broken or rubbing magnet d. Bad or worn bearing	i. Wait for warm weather i. Turn propeller gently by hand and blow or use piece of paper to dislodge debris i. Contact factory or distributor to remove rotor and re-glue magnets i. Contact factory or distributor to replace bearing(s)
2. Propeller will not turn at all except in high wind, scraping or rubbing sound at low rpm, always stops at same propeller position	a. Same as above, except more likely to be high magnet or bad bearing. b. Swelled wire keepers due to high moisture	i. Same as above i. Contact factory.
3. Propeller is harder starting, output is lower & there is more propeller noise than usual. Seems out of balance.	a. Ice on blade b. Dirty blade c. Split, warped or damaged blade d. One or more blades on backwards	i. Wait for warm weather. Prop will eventually shed ice, leave running unless there is substantial vibration i. Clean with mild detergent i. Contact factory or distributor to replace broken or damaged blade i. See blade installation
4. Propeller turns a little, never spins rapidly	a. Blades on backwards. (See blade installation)	i. Turn blades over. Leading edge advances clockwise from upwind view.
5. Tail, generator and tower vibrate or shake excessively at all or some wind speeds	a. Blade out of balance b. Blade not tracking c. Rotor (magnet can) out of balance d. blade plate out of balance	i. Contact factory to replace blade i. Contact factory to replace mounting plate i. Return to factory or distributor i. Return to factory or distributor
6. Rattle or clunking from generator	a. Generator loose in tower. Loose rotor (magnet can) on shaft, loose tail, missing rubber bumper, wires slapping inside of mast, governor pivot bolt loose. c. Worn bearings d. Shaft broken	i. Inspect for damage. Repair as required. Retighten mounting hardware, use Loctite or equivalent thread-locking compound. i. Contact factory to replace bearings i. Contact factory to replace shaft

ELECTRICAL DIAGNOSIS - DETERMINING THE TYPE OF ELECTRICAL PROBLEM

Electrical problems can be in the generator, wiring, or in the Whisper Controller. Determine which as follows:

1. **Wind generator will not start (blades turn slowly as if the diversion switch is engaged):** On a day of moderate wind, disconnect the three wires from the wind generator one at a time at the Whisper Controller. If the wind generator starts, the wire that allowed it to start leads to a failed component in the Whisper Controller. Call the factory or the distributor to replace the failed component.

OR

2. **Wind generator still does not start:** On a day of moderate wind, disconnect any two wires. If the wind generator starts, the problem is most likely in the Whisper Controller. Go to **Table: Symptoms of Whisper Controller Problems, page 33**. If the wind generator still does not start the problem is in the tower wiring or the wind generator. Go to **Table: Symptoms of Electrical Problems, page 32**

OR

3. **Wind generator is running, but may have an electrical problem:** As directed below, use a voltmeter to read the voltage across the leads and see the voltmeter test section below as a guide to possible problems.

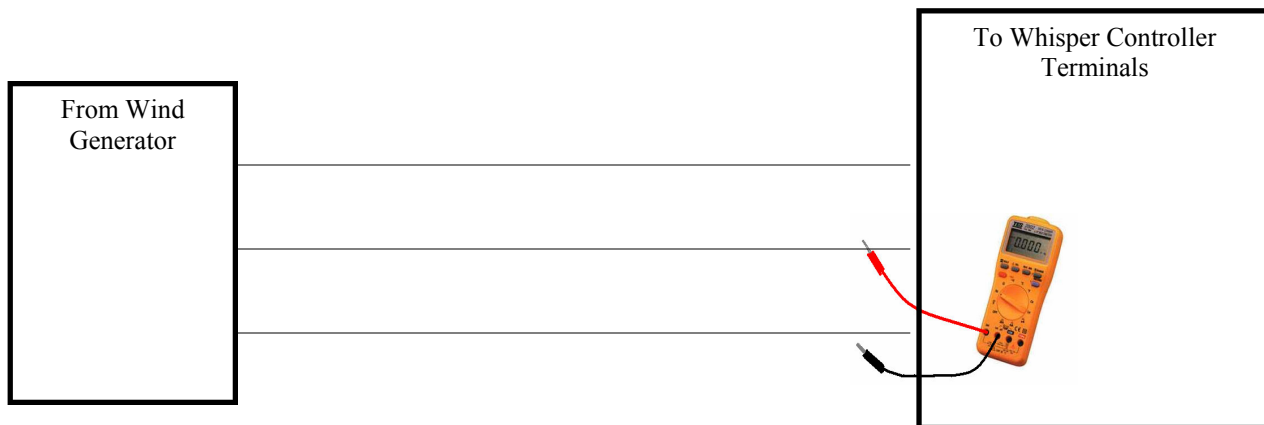

Voltmeter Test

1. Voltage increases and decreases slowly relative to the wind speed across all combinations of paired wires = Everything ok.
2. No voltage across two wires = One wire from wind generator not carrying power. Check in order: Check the tower wiring and Whisper Controller connections to insure proper wiring. If the wiring is correct contact authorized distributor or factory for further assistance.
3. Voltage significantly higher across two wires than the others = Contact the distributor or the factory, possibly a shorted diode.
4. Voltage significantly lower across two wires than the others = Bad connection at wind turbine voltage connections or faulty stator winding. Report this failure to your distributor or the factory.
5. Should these results appear inconclusive in determining the problem proceed directly to **Table: Symptoms of Electrical Problems, page 32**, or **Table: Symptoms of Whisper Controller Problems, page 33**.

Table: Symptoms of Electrical Problems

Symptom	Possible Cause	Correction
1. Propeller turns slowly even in strong wind, but will not start	<ul style="list-style-type: none"> a. Diversion switch is ON b. Battery is dead (voltage less than 1/2 nominal) c. Incorrect turbine wiring d. Short circuit in wiring from generator to Whisper Controller e. failed component in Whisper Controller f. Short circuit in brush card or slip ring assembly g. Short in turbine h. Load or battery disconnected 	<ul style="list-style-type: none"> i. Turn DIVERSION switch to BATTERY position. i. Disconnect loads and /or battery from Whisper Key until generator starts i. Rewire i. Check wiring from tower i. See "Voltmeter Test, page 31" i. Contact distributor or factory i. Contact distributor or factory i. Check all connections
2. Propeller runs too fast, may whistle, no output, no unusual mechanical noise	<ul style="list-style-type: none"> a. Two or three wires open between turbine and Whisper Controller. b. Whisper Controller diodes open or wire is disconnected at diode terminal 	<ul style="list-style-type: none"> i. See "Voltmeter Test page 31" i. See "Voltmeter Test page 31"
3. Propeller runs too fast, may whistle, low output, no unusual mechanical noise	<ul style="list-style-type: none"> a. Battery voltage over 50% high b. Turbine may be in regulation, but the wind may be too high for the turbine to stop 	<ul style="list-style-type: none"> i. Examine battery specifications and regulation set point, replace improperly-sized battery if necessary i. Wait for calmer conditions and engage diversion switch to determine proper operation
4. Propeller runs too fast, may whistle, output less than 50% for wind speed, growling, buzzing or vibration felt by hand or mast	<ul style="list-style-type: none"> a. Disconnected wire between the turbine and the Whisper Controller b. One open or disconnected diode c. One slip ring or brush not making good connection. 	<ul style="list-style-type: none"> i. See "Voltmeter Test, page 31" i. See "Voltmeter Test, page 31" i. Contact distributor or factory
5. Propeller runs too slowly, output low, no unusual mechanical noise	<ul style="list-style-type: none"> a. Battery voltage low, or a dead battery. b. Incorrect turbine wiring 	<ul style="list-style-type: none"> i. Disconnect loads and let battery charge. i. Check wind generator wiring connections or rewire

Table: Symptoms of Whisper Controller Problems

Symptom	Possible Cause	Correction
1. Propeller turns slowly, even in strong wind	<ul style="list-style-type: none"> a. Brake Switch ON b. Shorted diode c. Dead or disconnected battery d. Short in wiring to turbine 	<ul style="list-style-type: none"> i. Move switch to "OFF" i. Contact distributor or factory i. Insure battery voltage at Controller terminals is at least 10v, 20v, 32v, or 44v depending on turbine model i. See "Table of Electrical Problems" page 32.
2. Doesn't regulate, red LED off and dumpload is cold	<ul style="list-style-type: none"> a. Battery volts below setting b. Circuit Board bad 	<ul style="list-style-type: none"> i. Adjust setting. Check battery with voltmeter. i. Contact distributor or factory
3. Doesn't regulate, red LED on and dumpload is cold	<ul style="list-style-type: none"> a. Dumpload burned out or disconnected or wired wrong b. Bad connection from Circuit Board to power block 	<ul style="list-style-type: none"> i. Contact distributor or factory i. Contact distributor or factory
4. dumpload always on, red LED on	<ul style="list-style-type: none"> a. Wrong voltage setting b. Circuit Board bad c. Diversion switch set to "Stop" or battery disconnected. 	<ul style="list-style-type: none"> i. Adjust setting. Check battery with voltmeter. i. Contact distributor or factory

16. Mechanical Repair and Parts Replacement



Do not attempt these repairs on top of the tower. Perform repairs only after tower has been lowered.

BLADE UNMOUNTING

Remove blade, see Blade Installation, Section 12, page 20 (Disassembly is reverse order). Remove rotor bolts and blade strap. See exploded view.

Typical Blade Assembly

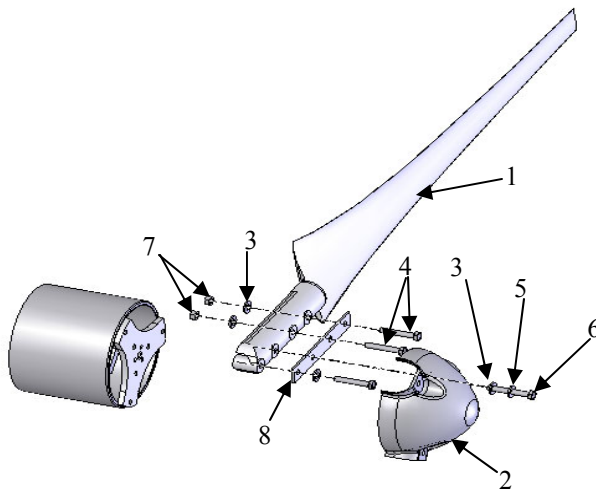

Item	Description	Quantity
1	Blade	3
2	Nose Cone	1
3	Flat Washer, M8 x 24	9
4	Hex Bolt, M8 x 50	9
5	Lock Washer, M8	6
6	Hex Bolt, M8 x 55	3
7	Nylock Nut, M8	6
8	Blade Strap	3

MECHANICAL REPAIRS AND PARTS REPLACEMENT

The following two sheets provide a complete exploded view and parts list of the Whisper 100. It is included as a guide for replacement parts and troubleshooting. It is, however, recommended that any internal repair of the turbine be performed by the factory or your authorized distributor. Any unauthorized attempt to repair the turbine leading to damage is not covered by warranty.

Exploded View Parts List-Whisper 100

#	LAND	MARINE	DESCRIPTION	Qty.
4	3-CMBP-1128-01		ROTOR ASSEMBLY	1
5	3-CMBP-1139		SPINDLE	1
6	3-CAOT-1066		SNAP RING	1
7	3-CABR-1003		BEARING OUTER, SEALED	2
8	3-CABR-1007		BEARING INNER, SHIELDED	2
9	3-CAOT-1065		SNAP RING	1
10	3-CMBP-1225-01	3-CMBP-1225-03	UPPER CASTING	1
11	3-CAOT-1051		BRONZE BUSHING	1
12	3-CMBP-1081		WIRE COVER	1
13	3-HDBT-2000—02		WIRE COVER SCREW	2
14	3-HDWA-102-10		FLAT WASHER	2
15	3-CMBP-1233		NYLON WASHER	1
16	3-HDNT-201-03		NYLOCK NUT M10	2
23	HDWA-200-07		M6 SPLIT LOCK WASHER	3
24	3-CMBP-1226-01	3-CMBP-1226-03	LOWER CASTING	1
25	3-CMBP-1228		BRUSH CARD &SONIC WELDED	1
26	3-CMBP-1055		BRUSH CARD COVER	1
27	3-CMBP-1109		BRUSH CARD GASKET	2
28	HDBT-2001-027		SCREW M5 X 60	4
29	3-CAOT-1156		RUBBER GROMMET	1
30	3-CAOT-1177		CONVOLUTE TUBING	1
31	3-CAOT-1160		CABLE CLAMP	1
32	3-CMBP-1177		1/4" NEOPRENE BUMPER	2
33	3-HDWA-904		BRONZE WASHER	2
34	3-ELOT-1012		TERMINAL FORK	1
35	3-CMBP-1194		YAW SHAFT ASSEMBLY	1
36	3-CAOT-1067		SNAP RING	1
42	3-CMBP-1122		PIVOT SHAFT	1
43	3-CMLB-1016		WIRING STICKER	1
44	3-CMBP-1198-01	3-CMBP-1198-02	STATOR	1
45		3-CAOT-1068	YAW SHAFT SEAL	1
46		3-HDBT-2003-031	PLUG SCREWS	3
47		3-CAOT-1076	SPINDLE SEAL	1
48		3-CAOT-1077	STATER PLUG	1
49	3-CAOT-1168		WIRE NUTS	5
50	3-CMBP-1054-01		BRUSH WITH SEAL	1
51	3-CAOT-1050		BRUSH SPRING	1

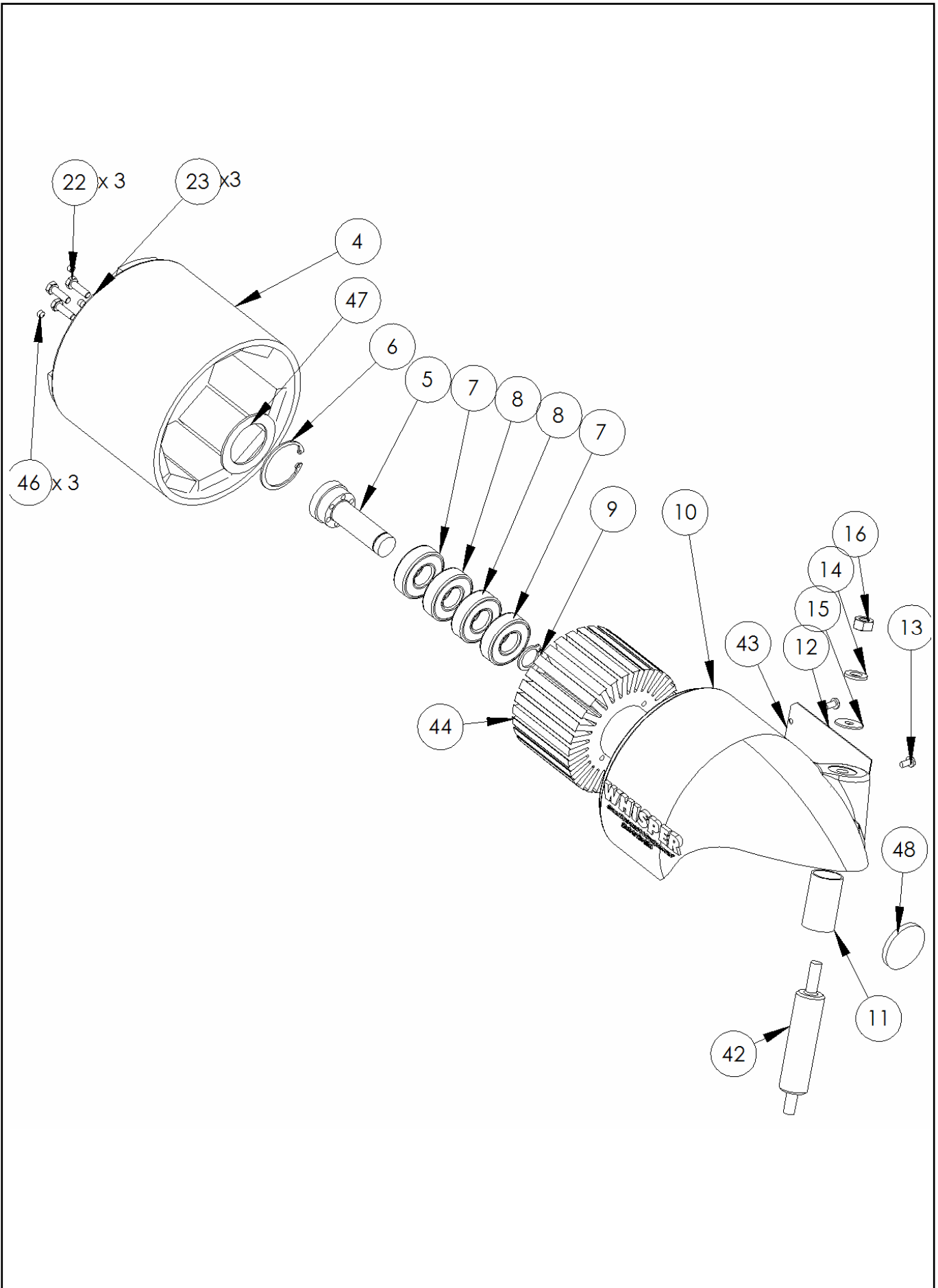

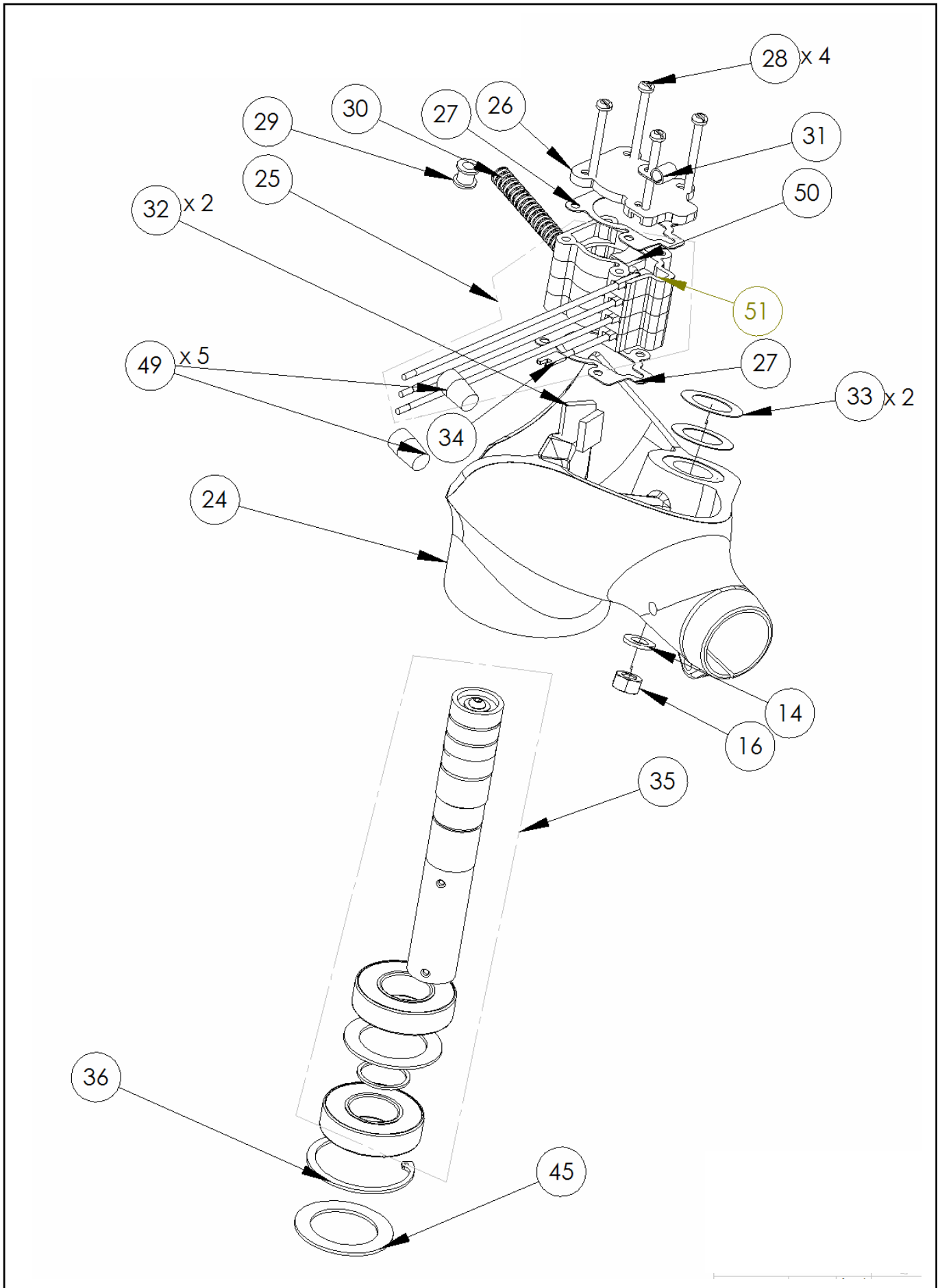

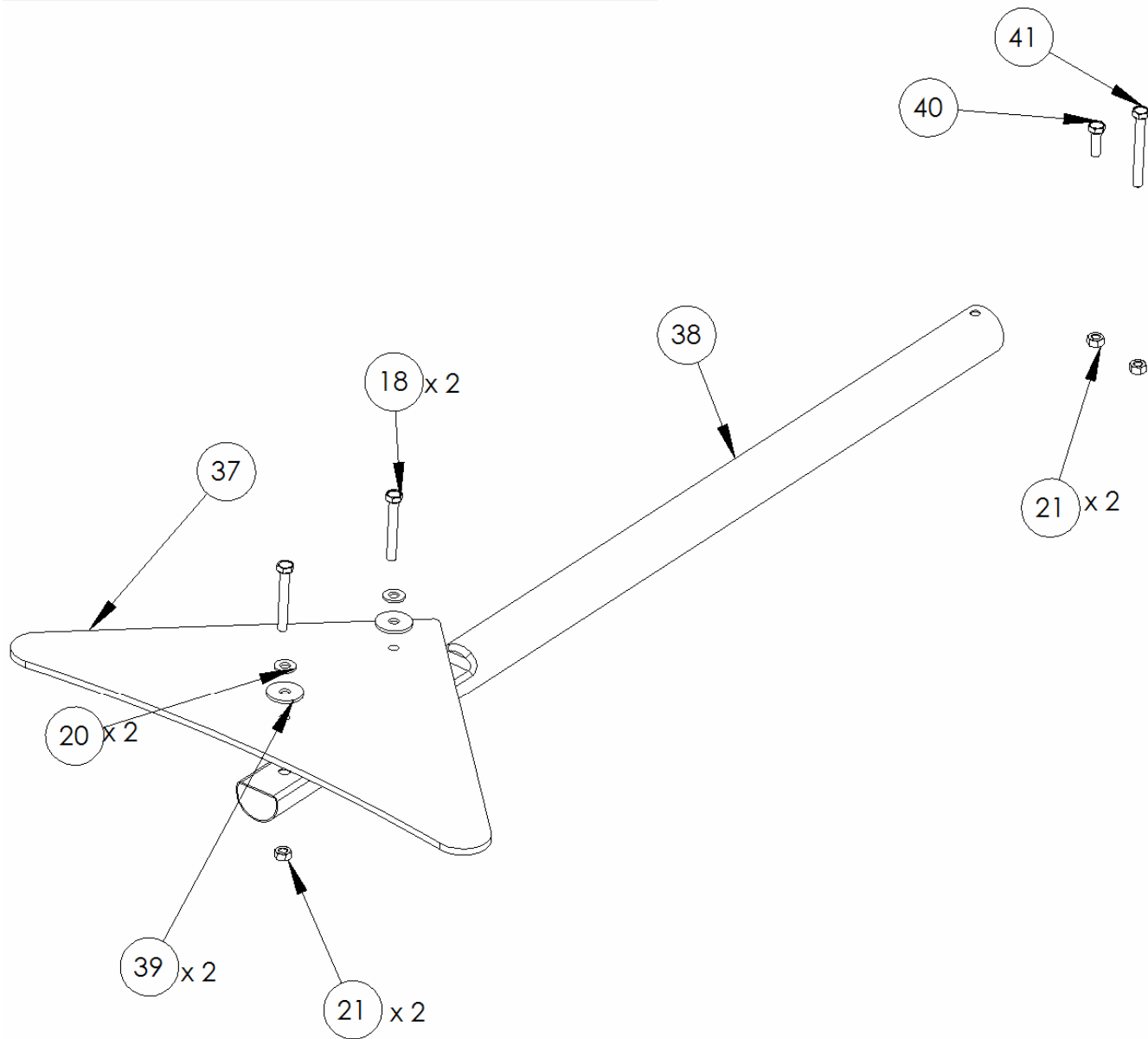

#	LAND	MARINE	DESCRIPTION	Qty.
18		3-HDBT-2006-074	BOLT M8 X 55	2
20		3-HDWA-201-09	M8 X 24 SS WASHER	2
21		3-HDNT-201-02	M8 SS NYLOCK	4
22		3-HDBT-2006-033	BOLT M8 X 20	3
37		3-CMBP-1142	TAIL FIN	1
38		3-CMBP-1180	TAIL BOOM	1
39		3-HDWA-905	M8 X 31 NYLON FLAT WASHER	2
40		3-HDBT-2004-069	BOLT M8 X 25	1
41		3-HDBT-2006-077	BOLT M8 X 70	1

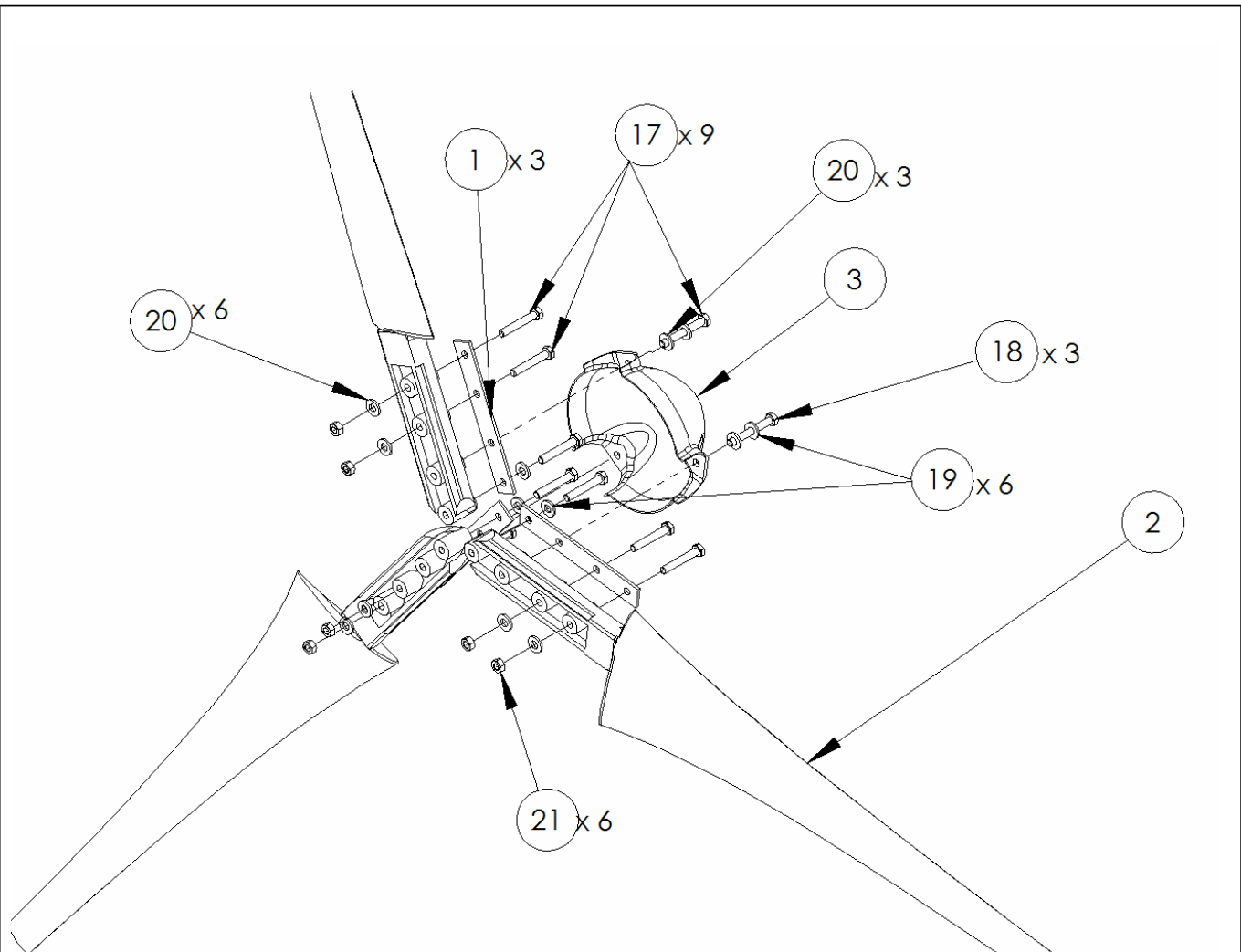

#	LAND	MARINE	DESCRIPTION	Qty.
1	3-CMBP-1041		H 40 BLADE STRAPS	3
2	3-CMBP-1200		BLADE SET	1
3	3-CMBP-1119		NOSECONE	1
17	3-HDBT-2006-073		BOLT M8 X 50	9
18	3-HDBT-2006-074		BOLT M8 X 55	3
19	3-HDWA-200-09		M8 SS LOCK WASHER	6
20	3-HDWA-201-09		M8 X 24 SS WASHER	6
21	3-HDNT-201-02		M8 SS NYLOCK	6