

50 FOOT LAND TOWER KIT
For WHISPER 100 AND 200 WINDTURBINES

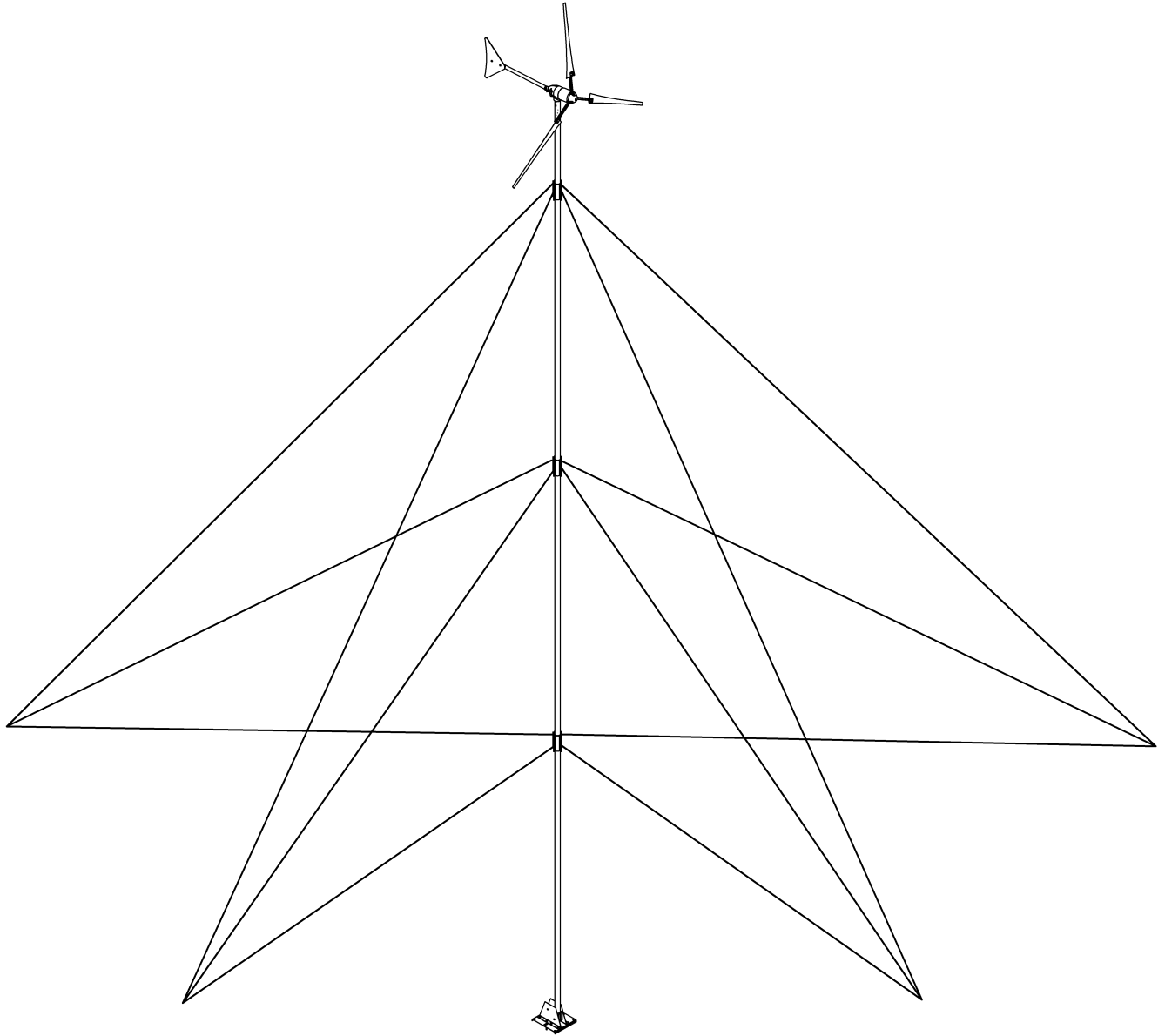

Made in the USA by:
Southwest Windpower
1801 West Route 66
Flagstaff, AZ 86001
(928) 779-9463

Whisper is a trademark of Southwest Windpower Inc.

50 FOOT WHISPER LAND TOWER KIT

CONGRATULATIONS! You have just received the simplest, most economical 50-foot tower kit available for your Whisper 100 or 200 wind turbine. This kit is designed to be very easy to assemble and erect, however it is important that you read this manual thoroughly before beginning assembly. If you have any questions on proper installation or usage please call either Southwest Windpower or your dealer for more information.

Notice: This information is believed to be accurate, however, Southwest Windpower assumes no responsibility for inaccuracies or omissions. The user of this information and product assumes full responsibility and risk. All specifications are subject to change without notice.

<u>CONTENTS</u>	<u>Page</u>
Introduction	3
Safety	3
Raising a Tower with a Gin Pole	4
Parts List	6
Tools Needed	7
Step 1: Site Selection	7
Step 2: Tower Pipe Selection	8
Step 3: Tower, Base and Anchor Layout	9
Step 4: Tower Base Assembly	10
Step 5: Guy Wire Anchor Installation	11
Step 6: Assembly of Tower and Turbine	14
Step 7: Attaching Guy Wires To Anchors	16
Step 8: Assembly of Gin Pole	17
Step 9: Raising the Tower	21
Step 10: Final Adjustment of Guy Wires	22
Step 11: Lowering the Tower	23

Introduction

This tower kit is designed specifically for the Southwest Windpower Whisper 100 and 200 wind turbines. To our knowledge this is the most economical and user-friendly tower kit available for the Whisper wind turbines. Three level, guy wire supported construction allows the use of lightweight tubing while providing plenty of strength, even in high wind conditions. With the help of a winch, beast of burden or vehicle, two people can easily erect the tower in a few hours. All that is required are a few tools, the necessary tubing and the proper anchors for your soil type. At least two people should be present to safely raise the tower.

This 50-foot (15 m) tower uses a gin pole to assist in raising the tower. The basic principle of gin pole use is described on the next two pages. This Whisper tower kit includes a custom made galvanized base with separate pivots for both the tower and gin pole. The tower base has a footprint of 16 inches square. In many cases a concrete pad for the tower base is not necessary.

A simple extruded aluminum coupling clamp allows the use of different wall thickness of tubing, depending on site requirements. Threaded coupling points are eliminated, allowing lighter materials to be used with the same or greater strength than a threaded pipe tower. The top guy wire attachment clamps onto the upper mast section. This reduces the number of pieces of tubing used to construct the tower and reduces the stresses concentrated at this point. Pre-cut and swaged guy wires eliminate wire measuring and cutting.

Thank you for purchasing our products and for your interest in renewable energy. We are confident that you will enjoy the benefits of your wind powered electrical system for many years to come. If, after reading this manual, you have any further questions please contact your local dealer or Southwest Windpower and we will do our best to assist you.

Safe Installation

Safety is the most important consideration to take into account when installing a tower and wind turbine. It is very important to remember that any wind turbine has high speed spinning parts and can be very dangerous if not installed properly! Be sure that the tubing or pipe used for the tower is of adequate strength, that all bolted connections are tightened to the proper torque and that the guy wire anchors are suitable for your conditions, terrain and size of tower. All of these elements are explained in further detail later in this manual. **Important! Choose a very calm day to do your installation. A gust of wind at the wrong moment could cause SERIOUS PROBLEMS!**

PLEASE.... READ THIS ENTIRE MANUAL BEFORE DOING ANYTHING!

Raising a Tower With a Gin Pole

A gin pole is essentially a smaller second tower that is used to gain the mechanical advantage necessary to raise your tower off the ground. The gin pole is raised first, with all of the guy wires on the front side of the tower (Lifting Guy Wires) attached to it. Ropes (“gin guy ropes”) are tied to the side anchors to stabilize the gin pole. (30 foot tower shown for clarity)

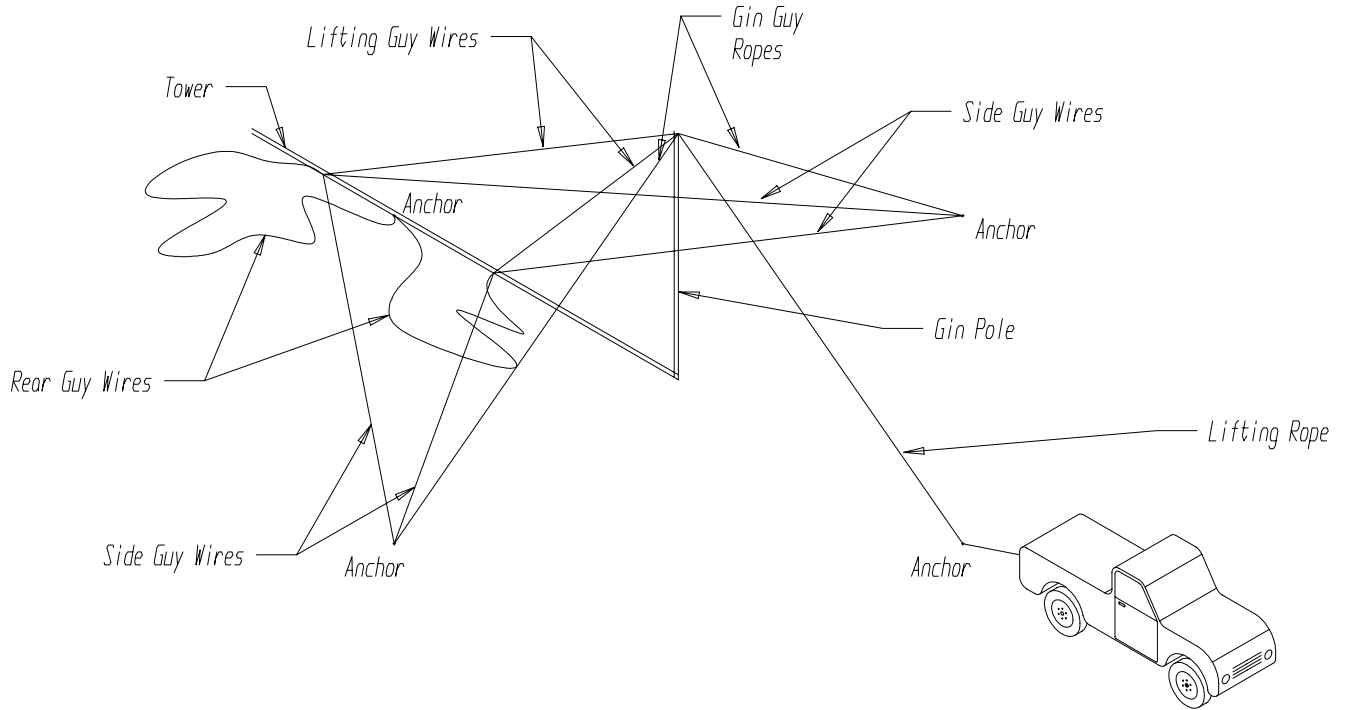

As tension is applied to the lifting rope (or cable) the tower will be raised off of the ground.

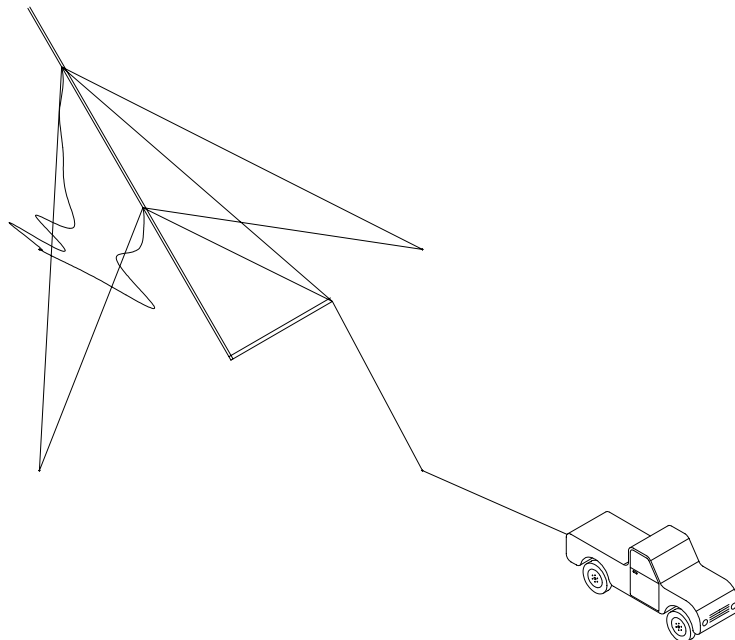

Pulling continues until the tower is vertical.

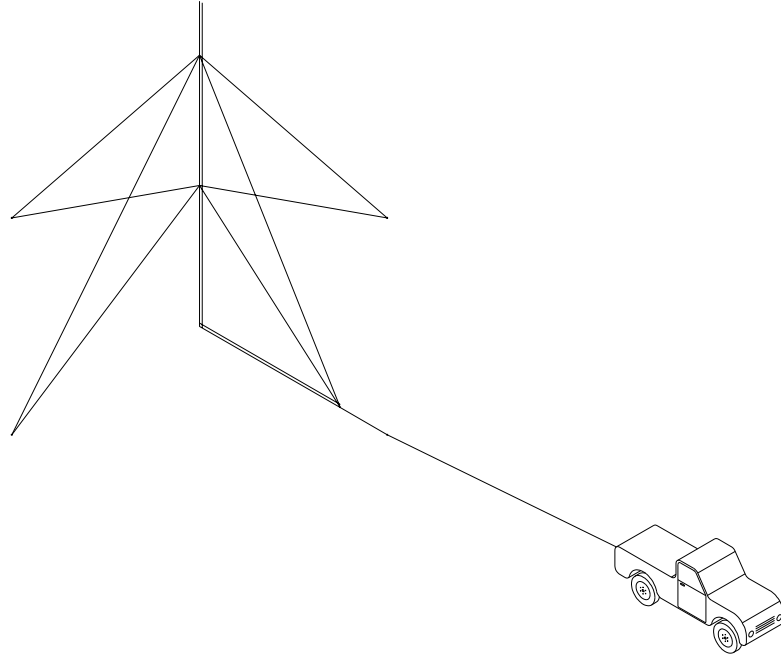

One at a time, the lifting wires are then removed from the gin pole top and attached to the lifting side anchor. The gin pole can be removed and used to erect other towers, stored until needed later or simply left attached.

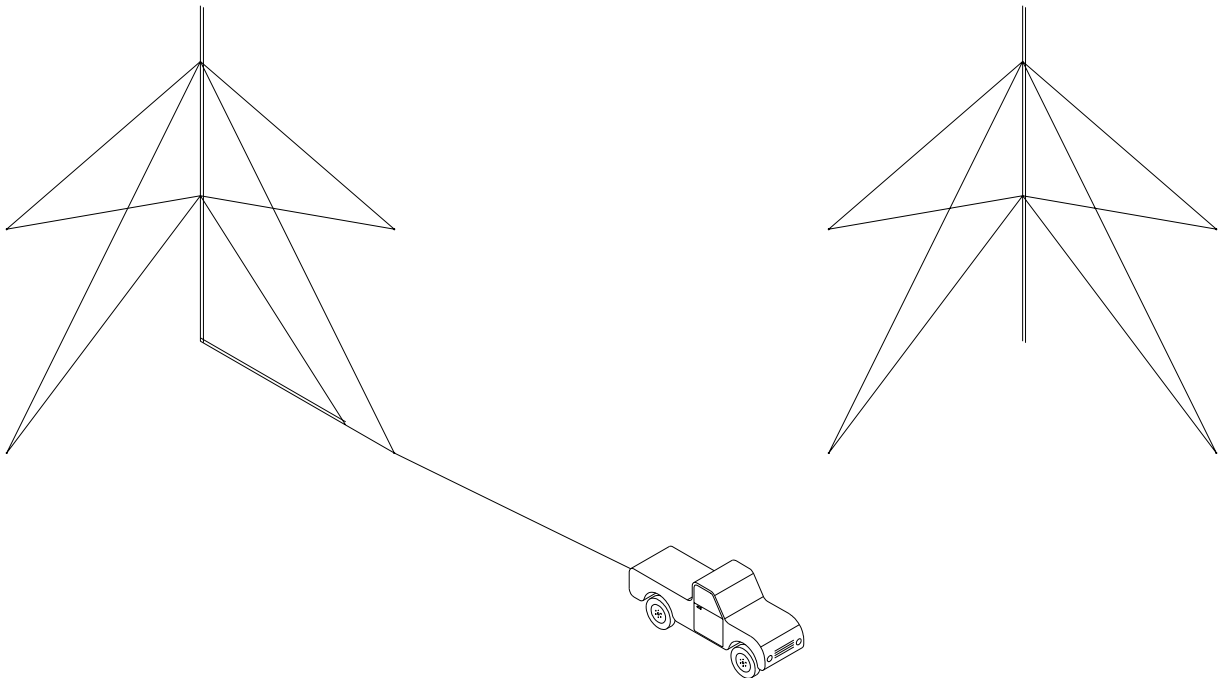

50 Foot Whisper Tower Kit Parts List

<u>Part</u>	<u>Quantity</u>	<u>Part</u>	<u>Quantity</u>
Tower Base	1	3/8" Carriage Bolts	8
Upper Guy Wire Set	1	Tower Insert (included w/turbine)	1
Middle Guy Wire Set	1	Pivot Bolt and Nut	2
Lower Guy Wire Set	1	Tower Base Coupler	1
3/8" x 2" Bolts	10	Gin Base Coupler	1
3/8" x 3 1/2" Bolts	6	Gin Pole Top Piece	1
3/8" Lock-nuts	24	4 link Chain	1
Cable Thimbles	12	Straight Connecting Link	1
Cable Clamps	36	Pear Connecting Link	1
Rope	100 foot		

Please inspect the contents to see that all parts are present and to familiarize yourself with the pieces before beginning assembly.

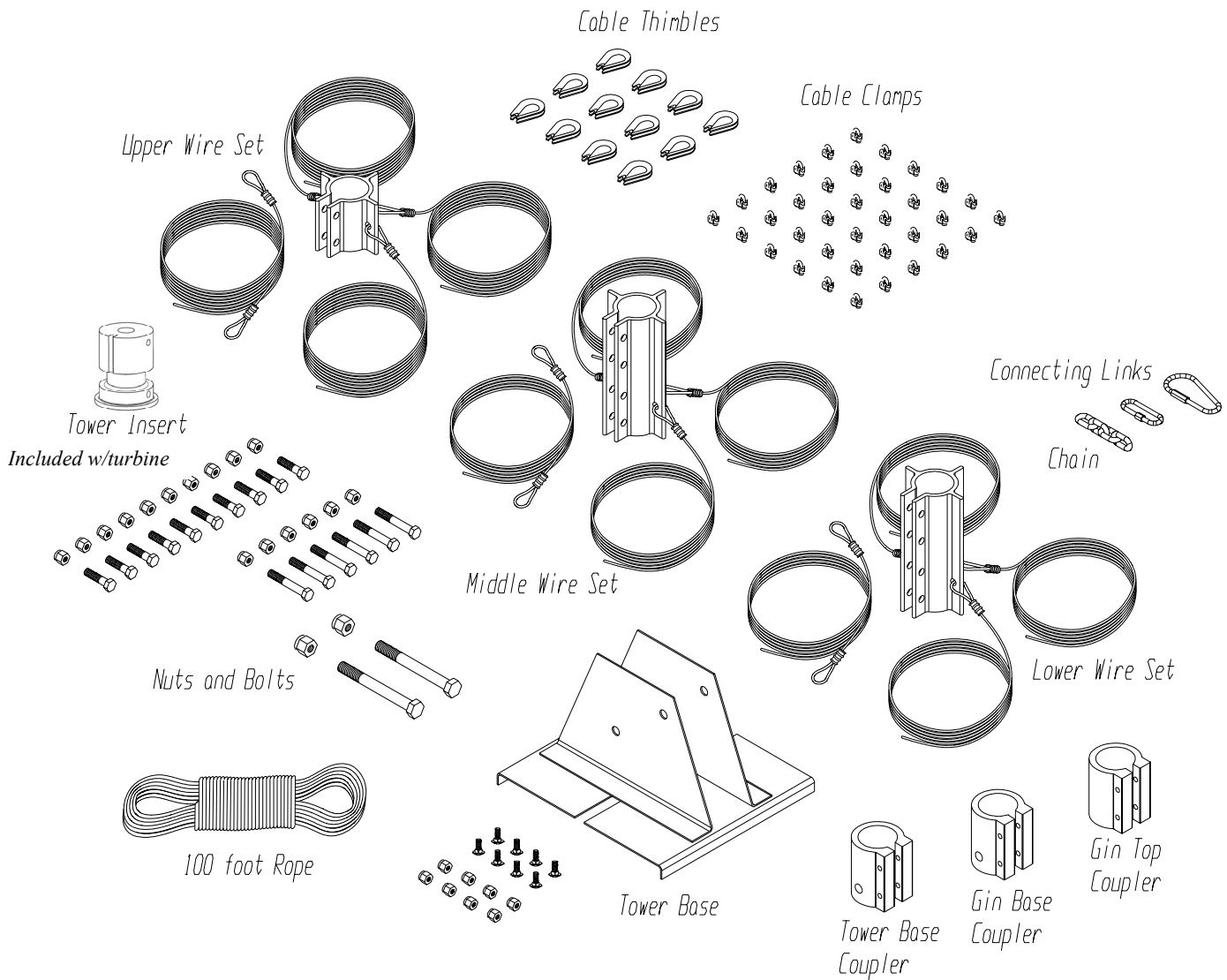

Necessary Items Not Included In This Kit:

Anchors (explained further in the “Anchors” section of this manual.)
 Tubing or Pipe for Tower
 Ground Rod and Clamp
 Lightning Arrestor*
 Electrical Wire
 Wire Connectors (preferably copper split bolts)
 Pipe Insulation (to prevent wire “rattle” inside pole) *
 Electrical tape
 Cable or Rope to raise tower (2000 lb strength x 100 feet (30m))
 Vehicle or Winch

* Optional items (these are explained in more detail in their relevant assembly sections)

Tools Needed:

Round or Half Round File	Pliers
Carpenters Level (optional)	(2) 9/16” or 15mm Wrenches/Sockets
Torque Wrench	Sledge Hammer
15/16” Wrench	Large Adjustable wrench
Sawhorse	Ladder or 10 foot (3 m) 2x6 or 2x8
3/8” or 10mm Corded or Cordless Drill Motor	3/8” or 10mm Metal Cutting Drill Bit

Step 1: Site Selection**Site selection is the most important factor affecting the performance of your wind turbine!**

The energy in the wind is the kinetic energy of the moving air mass. What a wind turbine does is convert some of that kinetic energy into rotational energy that can then be converted to electricity. The formula for the amount of power in the wind is a cube function of the wind speed. This means basically that an increase in wind speed of 10% (say from 9 mph to 10 mph) will result in approximately a 37% increase in the power available from the wind and a similar increase in turbine performance. In almost all locations the wind speed increases as you get higher off the ground. This is why a tall tower is very important at most wind sites. As a rule, the turbine should be mounted as high in the air and as far away from obstructions as is possible.

To find the best location to erect your tower and wind turbine, study the available area and take note of how the prevailing (most common) winds blow through it. If there are trees, buildings, hills or other obstructions take note of how high they are and where they are in relation to the prevailing wind direction. The best site for your tower and turbine will be upwind and above any obstructions that may exist. If there are houses or trees in the surrounding area a good rule of thumb is to mount the turbine at least 15 feet above any obstructions within 500 feet (150 m) of it.

The next consideration in siting your tower and turbine is the distance from the turbine to your batteries. The shortest distance will require the least amount of wire, allow use of the most economical (smallest) wire and reduce the amount of power lost. If a long distance is required

between your tower and the batteries it will be necessary to use a heavier gage wire to reduce the resistance of the wire. The power consumed by the wires can be calculated using the formula:

$$Power = Current \times Current \times Resistance$$

Since the resistance of the wire is directly proportional to its length, making the run shorter will dramatically reduce the amount of power “lost” in the wires.

Please refer to the section on “Tower, Base and Anchor Layout”. The amount of space available to assemble and raise the tower may also affect where your tower can be placed.

Step 2: Tower Pipe Selection

Because of the high cost of shipping and the widespread availability of the tubing or pipe used for our towers, these materials are not provided by Southwest Windpower. These materials are readily available through most chain link fence suppliers or plumbing companies and will cost much less when purchased locally than if we were to try to ship them from our factory.

The “Whisper” land tower kit is designed to use a 2.875 in. (73 mm) outside diameter pipe. This is the same outside diameter as 2 ½ in. steel water pipe where the “2 ½” is a nominal size indicating an outside diameter that is actually 2.875 in. Whether the pipe is “schedule 20”, or “schedule 40”, the outside diameter will be the same and the schedule number determines the wall thickness of the pipe. ***Use only structural steel for this tower! Never use electrical conduit!***

The design of this tower kit allows steel pipe (or tubing) of various different wall thickness to be used depending on its availability and on the severity of the wind at your site location. Use the following table to determine the acceptable pipe size(s) for your tower and wind severity. In most locations structural pipe with a wall thickness of .120 inches (3 mm) is sufficient for the conditions and preferable in terms of cost and ease of assembly. We recommend either “CQ-40” or “S-40” fence pipe available from any chain link fence supplier. Electrical conduit or plastic tubing should never be used in your tower assembly, since it is designed to be bent easily, not for strength.

Use the following table for Pipe / Tubing wall thickness guidelines:

Maximum Wind Speed	Recommended Wall Thickness	Pipe Schedule
80 mph. (135 kph)	.120 inch (3 mm)	CQ-40
100 mph. (160 kph)	.140 inch (3.6 mm)	S-40

Pieces of Pipe Needed:

- (2) **15 foot** (4.57 M) lengths of pipe for tower (wall thickness selected for local conditions)
- (1) **20 foot** (6.1 M) length of pipe for tower (wall thickness selected for local conditions)
- (1) **19 foot** (5.8 M) length of pipe for gin pole (.065” (1.6mm) or greater wall thickness)

****In some areas there are subsidies and grants available for installing renewable energy systems. If you live in one of these areas and need an engineering analysis for this tower assembly to satisfy your local authorities please contact us. We have an engineering analysis available for this tower kit.*

Step 3: Tower, Base and Anchor Layout

This tower kit must be assembled on a calm a day (no wind). The tower base and anchors should be laid out as shown in the drawing below.

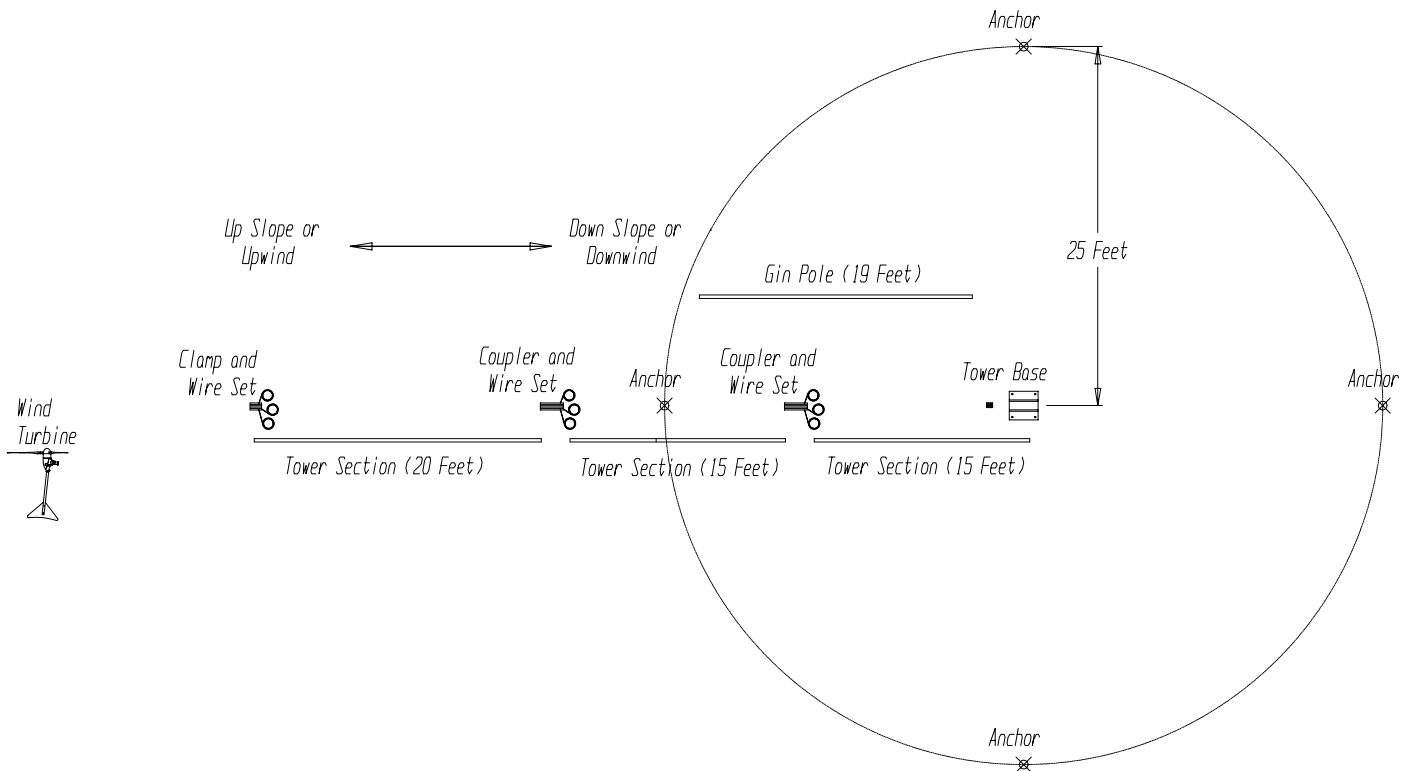

The tower will be assembled laying on the ground and then tilted up into position.

If the tower is being erected on the side of a hill it will be much easier to raise the tower if it is assembled to the uphill side of the base, as it will already be part way up once it is assembled. In this case the two “side” anchors should be at the same height or elevation on the hill. The two remaining anchors should be directly uphill and downhill from the tower base.

Be sure that the anchor points and base position are in a line when sighted from anchor to anchor. This will insure that the forces on the guy wires are balanced properly, make final guy wire adjustments simpler and will help a great deal during the actual raising of the tower. The side anchors and tower base should also be at the same elevation. If either of these requirements is not met, the guy wires will either tighten excessively or go slack as the tower is raised.

If the guy wires tighten excessively the tower may buckle and collapse, causing possible injury or even death and at the very least, damage to both the tower and the turbine. Carefully read the section on raising the tower for further instructions on making the proper adjustments in these situations.

Step 4: Tower Base Assembly

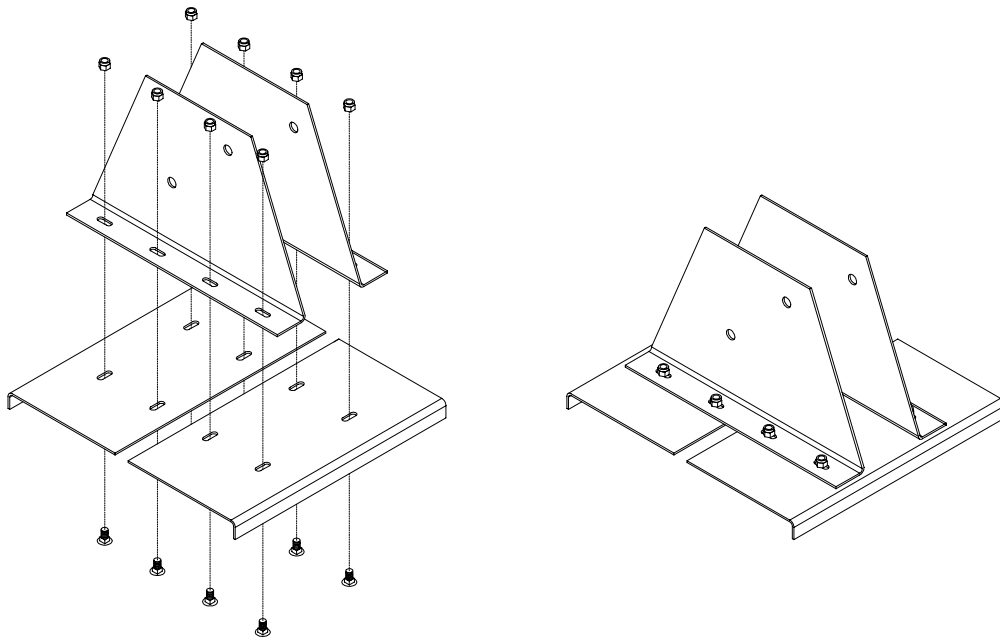

To assemble the tower base:

- 1) Start by matching the two “upright” pieces together as shown above.
- 2) Insert the large pivot bolt through the holes to assure proper alignment and install its nut finger tight. The two uprights should be assembled 4” apart. The tower base and gin base couplers can be used to help set this distance.
- 3) Bolt the two uprights to the two base plates using the carriage bolts provided (install the bolts from below, nuts from above).
- 4) Torque the nuts to 30-35 ft-lb (40-47 N-m)
- 5) Set tower base at desired location with lower pivot holes toward tower assembly direction.
- 6) Secure base with stakes or steel re-bar driven into the ground or bolts in concrete.

Step 5: Guy Wire Anchor Installation

There are four types of anchors that are most commonly used with our towers; screw in “Auger” type anchors, hammer driven “duckbill” anchors, cast concrete anchors and expansion bolts (for use only in solid rock). **What anchor should be used depends on the soil type that the anchors will be placed in.** See the following table for our suggestions:

<u>Soil Type</u>	<u>Recommended Anchor</u>	<u>Alternatives</u>
Sand or Cinders	Concrete	None
Loose Gravel	Concrete	None
Loam	Auger	Duckbill, Concrete
Clay	Duckbill	Auger, Concrete
Rocky Soil	Duckbill	Concrete
Gravelly Soil	Auger or Duckbill	Concrete
Solid (Soft) Rock	Large, Long Expansion Bolt	Large Eye Bolt + Cement
Solid (Hard) Rock	Smaller Expansion Bolt	None

The loads on a single anchor can approach 1,200 lb. in a 100-mph gale. Make sure that the anchors chosen can withstand at least this much force with a reasonable safety factor (1.5 or more) or the tower will have to be lowered during storms. Augers and Duckbill anchors are frequently available at mobile home supply stores. Augers are also available at the dealer where your turbine was purchased or from SWWP. Expansion bolts for anchoring in solid rock can be purchased at most hardware stores.

Augers: If the soil conditions make their use feasible, augers are the simplest anchors to install. Augers screw into the ground using either a piece of wood, pipe or rod as a “cheater bar”. If a mistake is made or if the tower must be removed an auger can be “unscrewed” out of the ground and reused. They depend on the soil holding together for their strength are not suitable for sand or loose gravel. If the soil is rocky or clay-like you may have difficulty screwing them in.

An auger is usually installed by screwing it straight into the ground a few turns to get it started and then tilting it to the desired angle once it is into the ground a few inches. A substantial downward pressure is usually necessary to get an auger started. Screw the augers in as far as possible for the greatest strength.

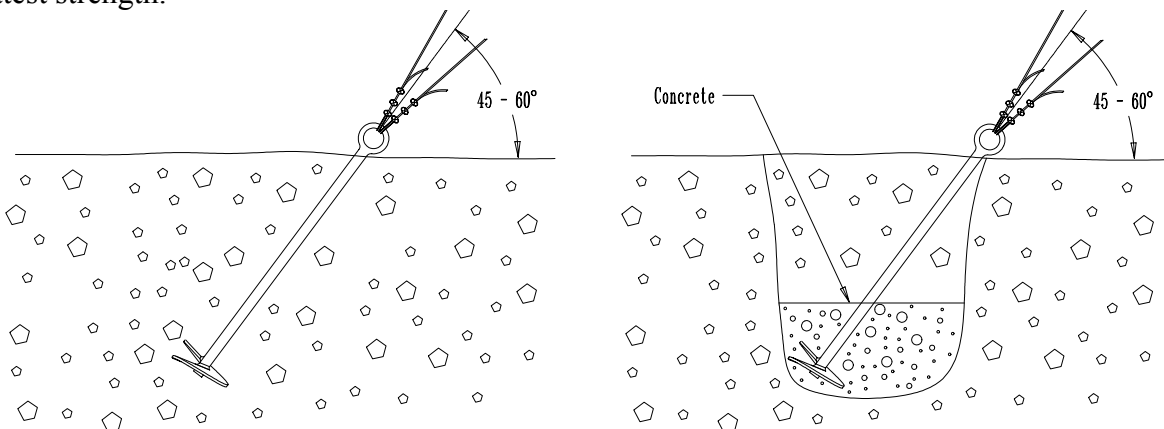

Augers depend on the ability of the soil to hold together for their strength. If augers cannot be screwed in, simply digging a hole and burying them will not work. We often recommend buying augers, and if they cannot be screwed in properly, a hole can be dug and the auger's disk can then be cast in the concrete. This will provide a good loop for guy wire attachment and make an excellent anchor in the concrete.

Duckbill Anchors: Duckbill anchors consist of an anchor attached to a cable with a loop on the end. They are driven into the ground using an anchor driver, which is a steel rod with either an enlarged striking surface (for a large hammer) or an attachment for a jackhammer or impact driver. The anchor driver fits into the anchor and holds it straight while it is being driven into the ground. Once the anchor is sufficiently deep in the ground, the driver is withdrawn and the anchor cable is pulled a short distance to "set" the anchor. As the anchor is being set it will rotate perpendicular to the hole made as it was driven in, making it very difficult to move any further.

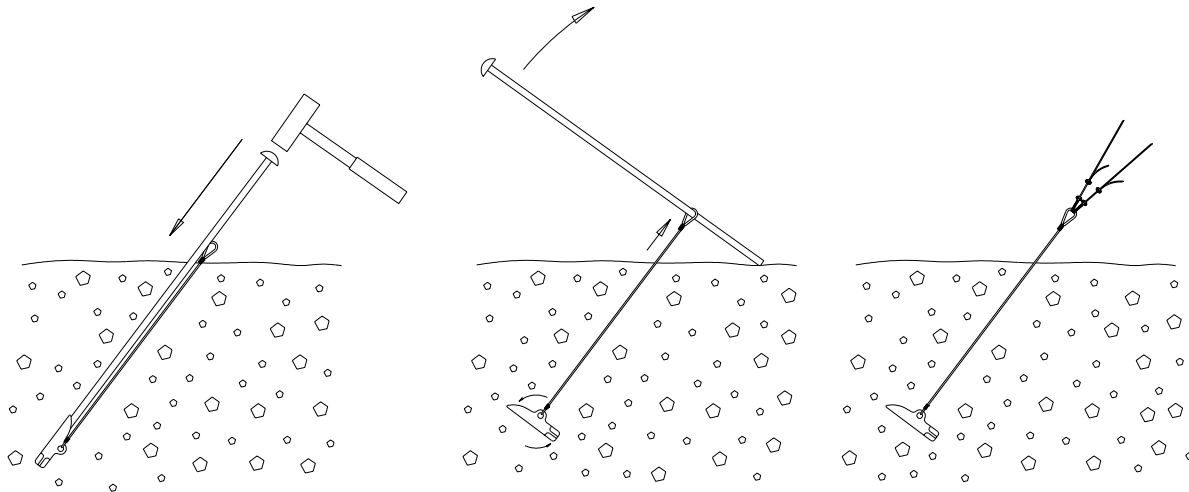

Please note that once a duckbill anchor is set in place it cannot be removed without digging it out.

Buried Concrete: A buried concrete anchor may be the only solution if the ground is loose gravel or sand or if it is too rocky for an auger or duckbill to be driven in. Buried concrete anchors work well in any situation other than solid rock. A hole must be dug in the ground at the desired anchor point. One good tactic is to purchase either augers or duckbills and if they cannot be used as intended, then dig holes and cast them in concrete. Otherwise some other means of attachment must be created for the guy wires, such as a loop of steel reinforcing bar (re-bar) or chain.

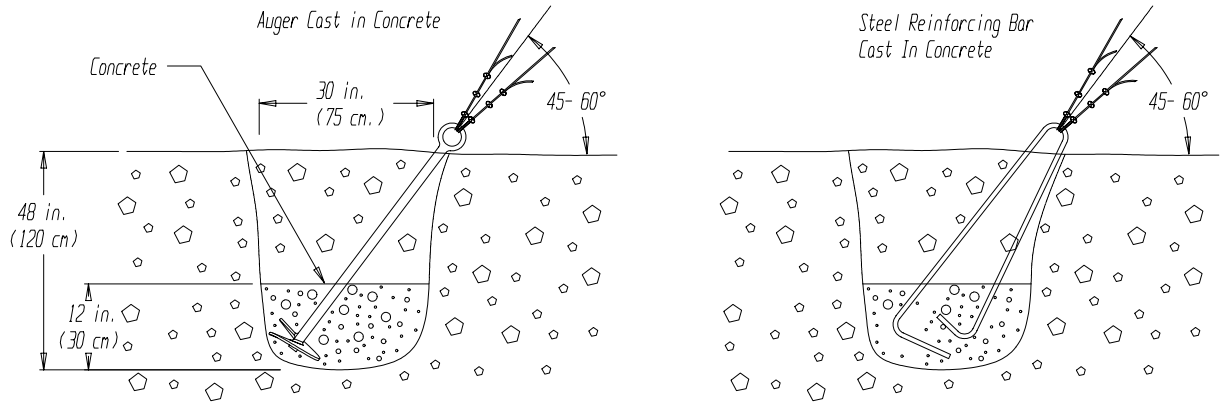

Holes for concrete anchors should be at least 30 in. (75 cm) in diameter and at least 48 in. (1.2 m) deep. The attachment should be placed in the hole and concrete or cement poured around it to a depth of at least 12 in. (30 cm). Once the concrete has cured (see instructions supplied with your concrete for curing times) it should be re-covered with soil that is then packed or tamped down before use.

Anchoring in Rock: If your tower site has large rocks around it or is located on solid rock, expansion bolts in the rock may be the best means of anchoring your guy wires and tower base. A hole is drilled into the rock and the bolt is placed in the hole with an attachment hanger, a piece of chain or other loop to connect to the guy wires.

For expansion bolts to work properly the rock must be of good quality and not fracture easily. If the rock quality is poor a larger deeper hole must be drilled and a large eye-bolt cemented into it. For very hard rock such as granite and basalt, a 3/8-inch (10 mm) diameter bolt 3 inch (7 cm) deep can be used. For slightly softer rock such as dacite, welded tufts and some denser varieties of sandstone, a 1/2-inch (13 mm) diameter bolt 4 to 6 inches (10-15 cm) deep can be used.

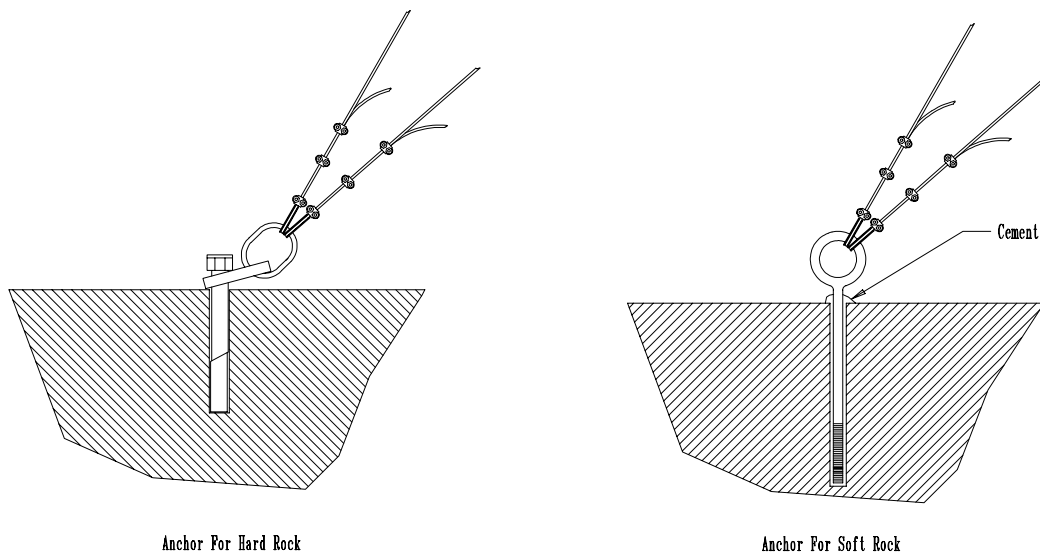

For softer types of rock, such as sandstone or limestone, a hole 1-inch (25 mm) diameter and 8 inches (20 cm) deep can be drilled and an eyebolt 5/8 inch (16 mm) in diameter cemented into it. The cement should be mixed just thin enough to pour and poured into the hole before the bolt is installed (a straw inserted to the bottom of the hole before pouring will help prevent a bubble from forming). This will help to insure that the cement goes to the bottom of the hole and help prevent bubbles that may compromise the strength of the attachment. If expansion bolts are to be used, follow the instructions supplied with the bolts. There are several different types of expansion bolts that are installed using different methods.

Step 6: Assembly of Tower and Turbine

- 1) Insert pivot bolt (5/8" x 5") through the pivot holes in the tower base coupler.
- 2) Install the tower base coupler onto one end of a 15-foot tower pipe so that the pivot bolt

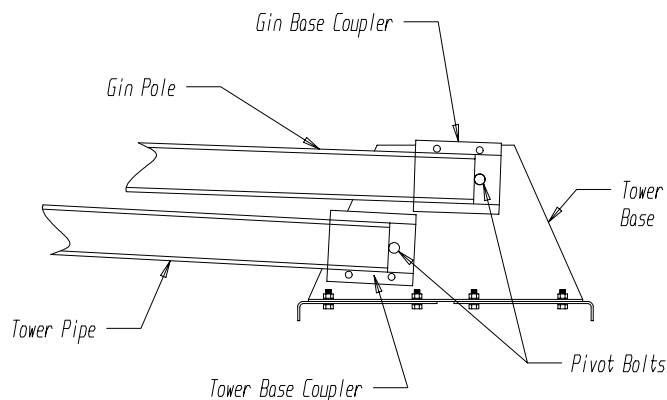

touches the end of the tower pipe. Torque the two pinch bolts to 45-50 ft-lb. (60-68 N-m) and withdraw pivot bolt.

- 3) Lay the tower pipe on the ground and locate the base coupler into the tower base with the clamping side of the coupler facing down.
- 4) Align the base coupler with the lower pivot hole in the tower base and install the pivot bolt through the base and coupler. Tighten the nut onto the pivot bolt so that it is snug, but not tight.
- 5) Install the lower guy wire set and coupler (the tall coupler marked "501") onto the upper end of the first 15-foot pipe section, but do not tighten the bolts yet. The guy wires are attached to the coupler toward one end of the coupler. This end of the coupler must be oriented toward the base of the tower.
- 6) Install the middle guy wire set and coupler (the tall coupler marked "502") onto the upper end of the second 15-foot pipe section, but do not tighten the bolts yet. The guy wires

attach to the coupler toward one end of the coupler. This end of the coupler should be oriented toward the base of the tower.

- 7) Install the upper wire set (the short clamp marked “503”) onto the upper tower pipe. The center of the clamping piece should be located 5 feet (1.52 m) from tower top. Torque the two bolts to 40-45 ft-lb. (54-60 N-m). Repeat the tightening sequence three times.
- 8) Prepare the turbine electrical wires by straightening them so they will slide through the tower pipes more easily and laying them out where they will be fed into the tower pipes. If desired, short pieces of foam insulation made for water pipes can be taped onto the wires at 3 foot (1 m) intervals to reduce wire noise transmitted through the tower itself.
- 9) Run the turbine wires through the three tower pipes, one pipe section at a time. Taping the ends of all three wires together makes this easier.
- 10) Join the lower two pipe sections together, positioning the center of the coupler directly over the seam between upper and lower pipe sections. Torque the four pinch bolts to 40-45 ft-lb. (54-60 N-m), repeating the tightening sequence at least four times.
- 11) Join the upper pipe section to the tower, positioning the center of the coupler directly over the seam between the two pipe sections. Torque the four pinch bolts to 40-45 ft-lb. (54-60 N-m), repeating the tightening sequence at least four times.
- 12) Raise the turbine end of the upper tower pipe and set it on a saw horse or other supporting object. The end of the tower should be at least 3-4 feet (1 m) off the ground. Drill holes in tower pipe using supplied template. *A tower drilling template is included as the last page of this manual.*
- 13) Install the round tower insert onto the turbine’s yaw shaft. Tighten the two set screws to 4-5 ft-lb. (5-7 N-m)
- 14) Connect the turbine electrical wires to the turbine using split bolts or solder. Insulate well with electrical tape or heat shrink tubing.

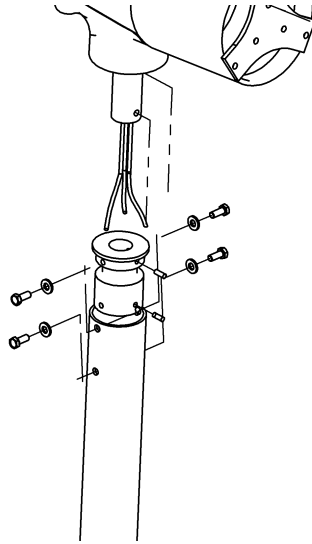

- 15) Lift the turbine into position and install the tower insert on the turbine into the end of the tower. It will help to have someone pull the slack out of the turbine electrical wires as the turbine is being moved into position.
- 16) Make sure the bottom of the tower insert is touching the top end of the tower pipe. Insert and torque all four insert mounting bolts (M8 x 20mm) to 10-11 ft-lb. (12-14 N-m) repeating any tightening sequence used at least four times to insure the lock washer is flattened.

Step 7: Attaching Guy Wires to Anchors

With the assembled tower lying on the ground (or on saw horse) the guy wires at the sides and rear of the tower should now be attached. Leave about 3 inches (8 cm) of slack in the wires to allow for any misalignment or unnoted elevation differences (the wires will be adjusted more precisely later). The side wires can be pulled to their anchors and attached using the wire rope thimbles and cable clamps provided with your tower kit.

Note: The thimbles may need to be spread open to install them on your anchors. This can be done by twisting with a pair of pliers and the end of one of the tower tubes. Be sure to press the open end of the thimbles back together (with pliers) before attaching the guy wires.

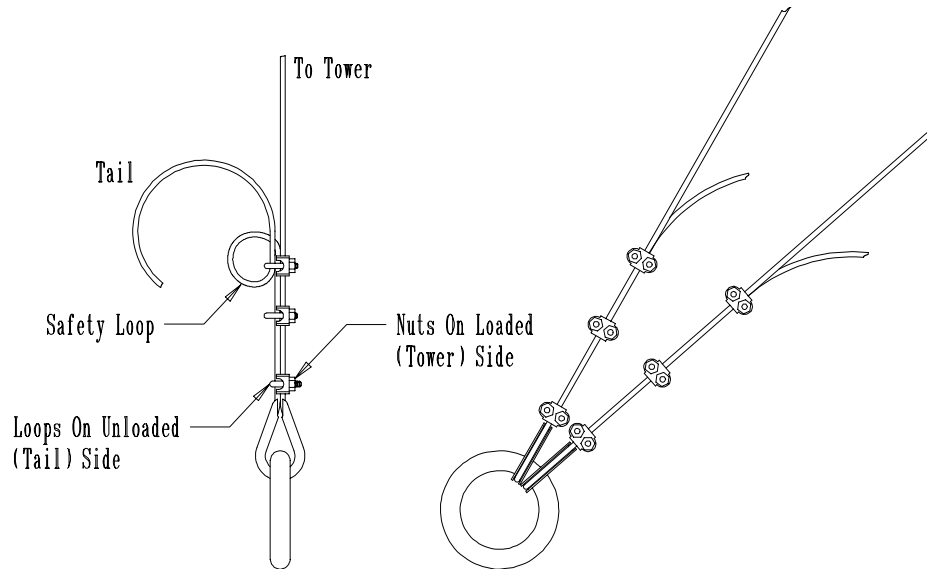

The rear wires length can be estimated by pulling them to a side anchor and placing a piece of tape on the wire at the distance of the side anchor. The rear wires will then be attached to their respective anchor at the point marked by the tape. This should make their length approximately correct when the tower is up (again these will be readjusted, so don't worry about a couple of inches (5cm) one way or the other). Make sure that none of the guy wires are crossed and that the side wires are straight with no rear wires on top of them. Run the tail end of each guy wire through the second clamp twice, forming a safety loop. Attach all of the side and rear wires securely as shown in the drawing with three clamps on each wire. Use 15-16 ft.-lb. (20-21 N-m) of torque on each nut. It is important (for good strength) that the saddle and nuts part of each clamp is on the loaded (tower) side of the guy wire.

MAKE SURE THAT ALL GUY WIRES ARE SECURE BEFORE PROCEEDING!

At this point the turbine should be propped up on a box, chair, stool or milk crate so that the blades are not damaged when they are installed. Mount the blades and tail onto the turbine at this time, following the procedures describe in the turbine manual.

Step 8: Gin Pole Assembly

The use of a gin pole makes raising your tower much easier than without one. All parts and hardware needed for your gin pole are included in this kit. For the 50 foot tower kit a 19 foot length of 2 ½" pipe (2.875" (73mm) actual outside diameter) is needed for the gin pole (see pipe information on page 8). The gin pole will be assembled lying on top of the tower pipe itself. It uses the upper set of holes in the tower base. Assembly is as follows:

- 1) Insert pivot bolt (5/8" x 5") through the pivot holes in the gin base coupler.

- 2) Install the gin base coupler onto the bottom of the gin pole so that the pivot bolt touches the end of the pole. Torque the two pinch bolts to 45-50 ft-lb. (60-68 N-m) and withdraw pivot bolt.
- 3) Lay the gin pole on top of the tower pipe and locate the coupler into the tower base with the clamping side of the coupler facing up.
- 4) Align coupler with the upper pivot hole in the tower base and install the pivot bolt through the base and coupler. Tighten the nut onto the pivot bolt so that it is snug, but not tight, against the tower base.
- 5) Assemble and install the gin pole top piece (clamping side up) with the chain and connecting links as shown below. Torque the two bolts to 40-45 ft-lb. (54-60 N-m).

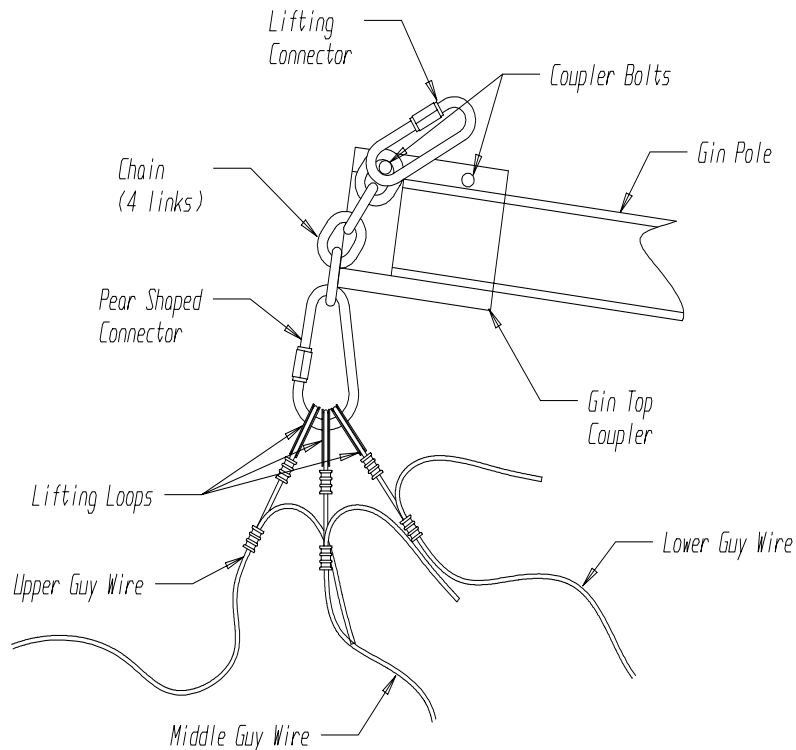

- 6) Attach the three “lifting wires” to the pear shaped link at the gin pole top. Make sure they are not crossed or tangled and will pay out cleanly when the gin pole is raised.

- 7) The 100-foot (30m) rope will serve as guy wires for the gin pole as it is raised. Tie one end of the rope to each of the two side anchors. Pull the rope tight from each anchor and tie to the lifting connector on the gin pole. A loop will hang from the gin pole if this is done correctly. The rope could be cut in half, but it is not necessary.

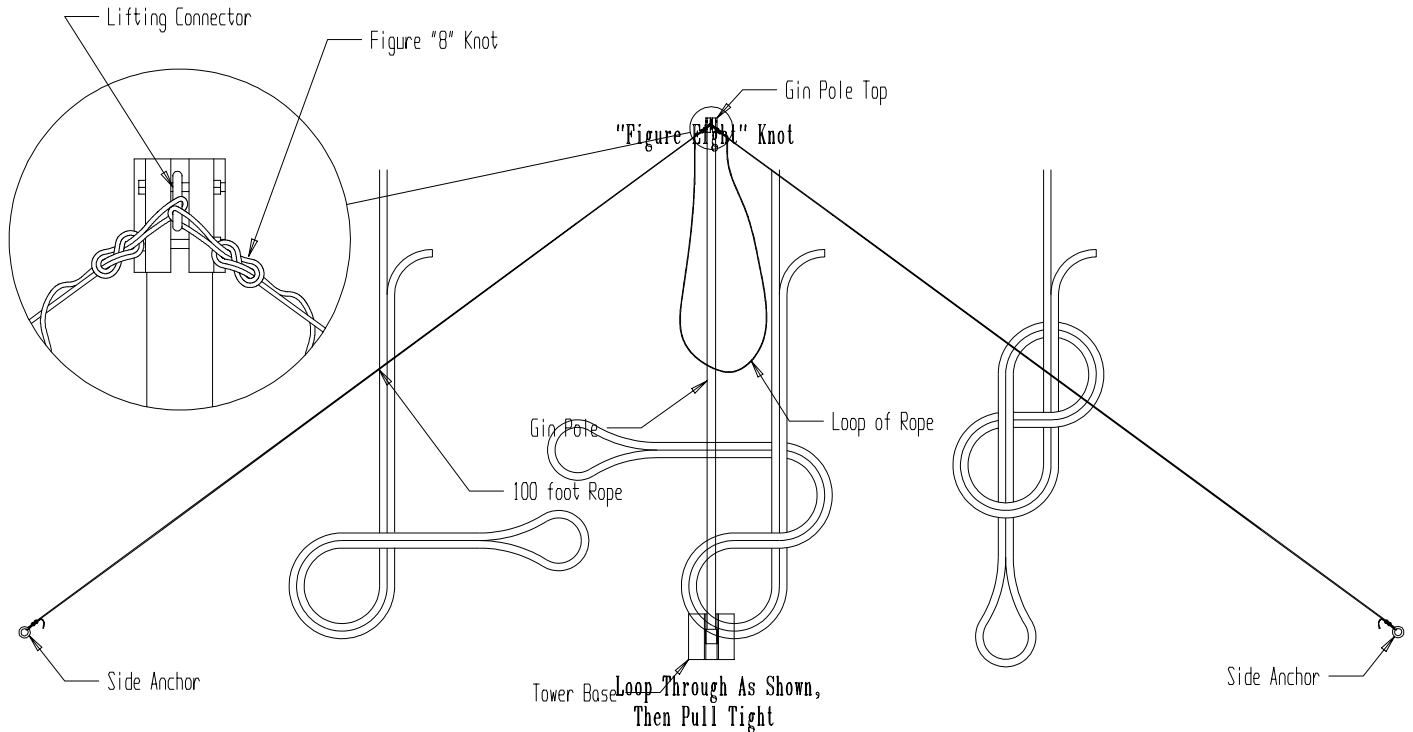

- 8) Figure eight knots are simple and effective for the ends of the rope attached to the anchors and lifting link.
- 9) Prepare winch or vehicle and attach a lifting cable or rope from the vehicle to the lifting link at the gin pole top (lifting rope should test to at least 1,000 lb or 450 kg for safety).
- 10) Run lifting rope or cable through a snap link or the eye of the anchor you are pulling toward.

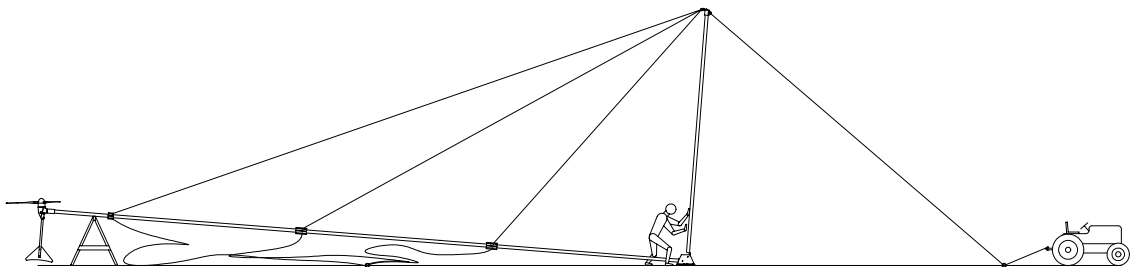
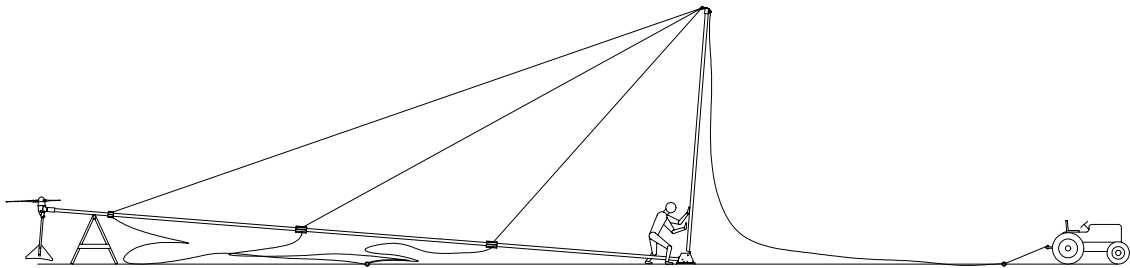
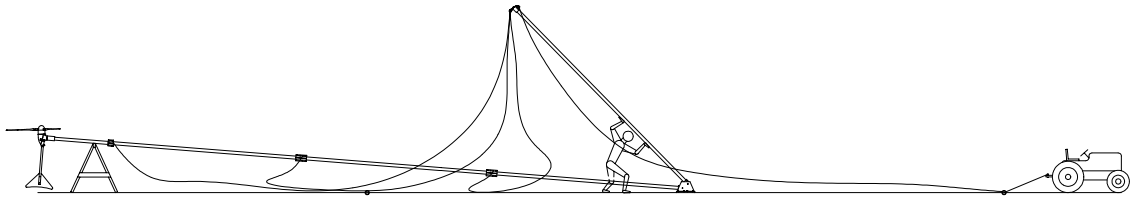

- 11) Raise the gin pole manually until it is just past vertical and the lifting guy wires are tight.
- 12) Hold the gin pole while slack is removed from the lifting rope or vehicle is moved forward to take out the slack

Step 9: Raising the Tower

Before attempting to raise the tower make sure that all side and rear guy wires are attached and that all cable clamps are tight. Also be sure that the two bolts on the guy wire hanger are tight.

- 1) Slowly proceed until the tower lifts off of the sawhorse. Pull the tower up about 15 degrees at a time, stopping each time to see if any of the side guy wires are getting too tight. If they are too tight the tower will begin to bow. This is usually caused by the ground at the base being slightly higher than the ground at the side guy wire anchors, or if the anchors and the base are not in a straight line. If this occurs immediately lower the tower back to the ground and adjust the side guy wires a few inches looser.

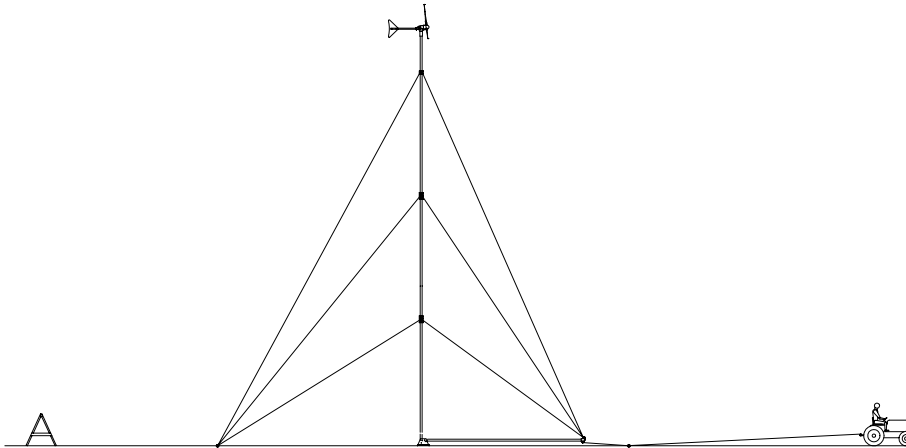
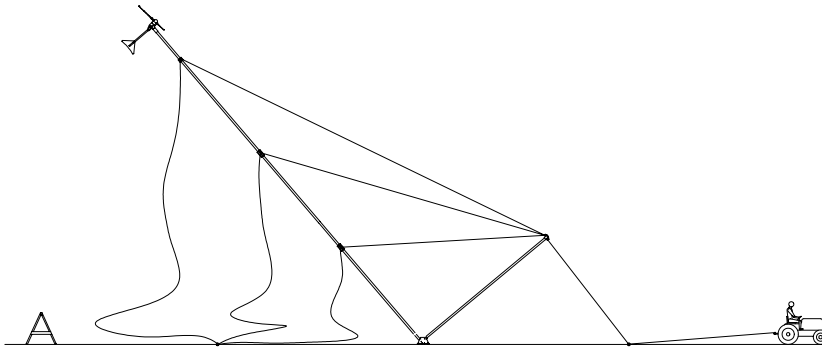
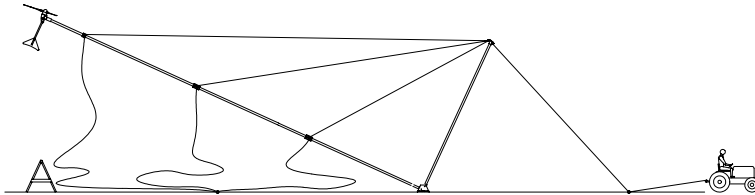

Failure to adjust the guy wires properly before raising the tower may cause the tower to buckle and collapse, seriously damaging the turbine and tower and possibly causing serious personal injury or death!

- 2) Continue forward until tower is vertical, stop vehicle, set brake, leave in gear and shut off engine.

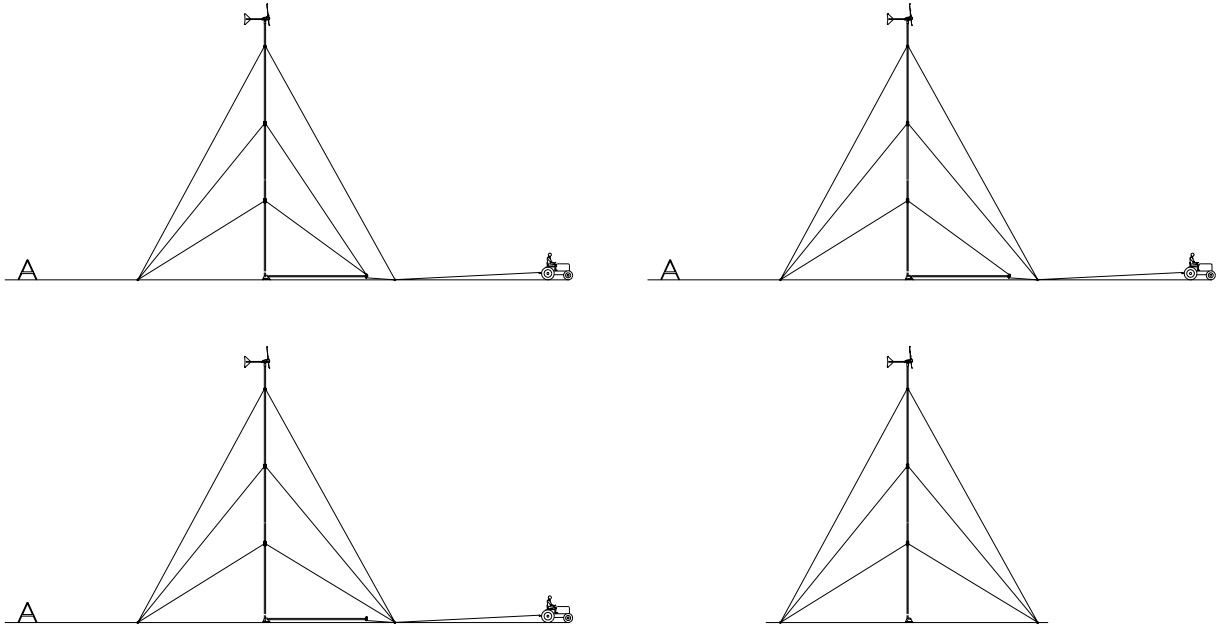

- 3) One at a time working from the upper guy wire down, remove the lifting wires from the pear shaped connector and attach them to their anchor.
- 4) The gin pole can now be removed if desired.
- 5) At this point the tower should be checked for guy wires that are slightly too tight or too loose. Guy wires that are too tight will cause the tower to bow. If they are too loose the tower will usually sway back and forth a bit. The proper tension is where there is no tension and no slack. This is easily achieved by hand without turnbuckles. Correct any obviously mis-adjusted wires by loosening their cable clamps one at a time, adjusting the wire and re-tightening the clamps.

Step 10: Final Adjustment of Guy Wires

First look to see if any of the guy wires are too tight and are causing the tower to bow. A tower with slightly loose wires is safer than a tower with wires that are too tight. If there are, determine which wire(s) are too tight (the wires act in pairs) and release the tension on one of the wires. To relieve tension on a wire, loosen the three cable clamps until the cable can be slid through them.

The tension on the wires should be very light and can be set by pulling the wire by hand. It is easy to over tighten the guy wires, even by hand. Be sure to re-tighten the cable clamp nuts. Repeat this

for the upper and lower tower sections until the tower is no longer bowed. Proper torque for the nuts on the cable clamps is 15 to 16 foot-lb (20-21Nm).

Now walk a short distance from the tower and look to evaluate whether the tower is straight or leaning to one side (a carpenter's level held against the tower can be helpful for this). You will probably need to relax one wire and tighten the wire opposite to it, then check the tower straightness and repeat the process until the lower tower section is straight.

When you are done, make sure that all the cable clamps are tight. If the tower is to be lowered, only unclamp the cables on the lifting wire side so that when the tower is re-erected only those cables will need to be readjusted.

Grounding

To properly ground the tower to the earth a ground rod (usually copper plated steel) should be installed as close to the tower base as possible. A #10 AWG or larger, solid copper wire should be attached to the tower pipe near the bottom of the tower and to the ground rod.

Maintenance

Periodically check to see that the guy wire tension is set properly. Typically there is no other maintenance required for this tower. Keep your setup kit in a safe place in case the tower needs to be moved or the turbine requires service.

Step 11: Lowering the Tower

- 1) Disconnect your turbine wires at the controller.
- 2) "Short" the wires together to stop the turbine from spinning
- 3) Reassemble gin pole and attach the lifting rope or cable to it in the same manner as when it was used to raise the tower.
- 4) One at a time, working from the lowest wire upwards, remove the lifting guy wires from the guy wire anchor and attach them to the pear shaped connecting link at the top of the gin pole.
- 5) Position a sawhorse where the tower is expected to come to the ground to protect the turbine blades from damage.
- 6) Tip the tower by hand until the lifting wires and main lifting cable or rope are taut and supporting the tower.
- 7) Slowly lower the tower until it is resting on the saw horse.

This Page Intentionally Left Blank

Proprietary rights are included in the information disclosed herein. This information is submitted in confidence and neither the document nor the information disclosed herein shall be reproduced or transferred to other documents for manufacturing or for any other purpose except as specifically authorized in writing by Southwest Windpower.

REVISIONS			
REV.	DESCRIPTION	DATE	APPROVED
NC	initial release	sep 0	DAJ
A	sheet resized	dec 3	JGL

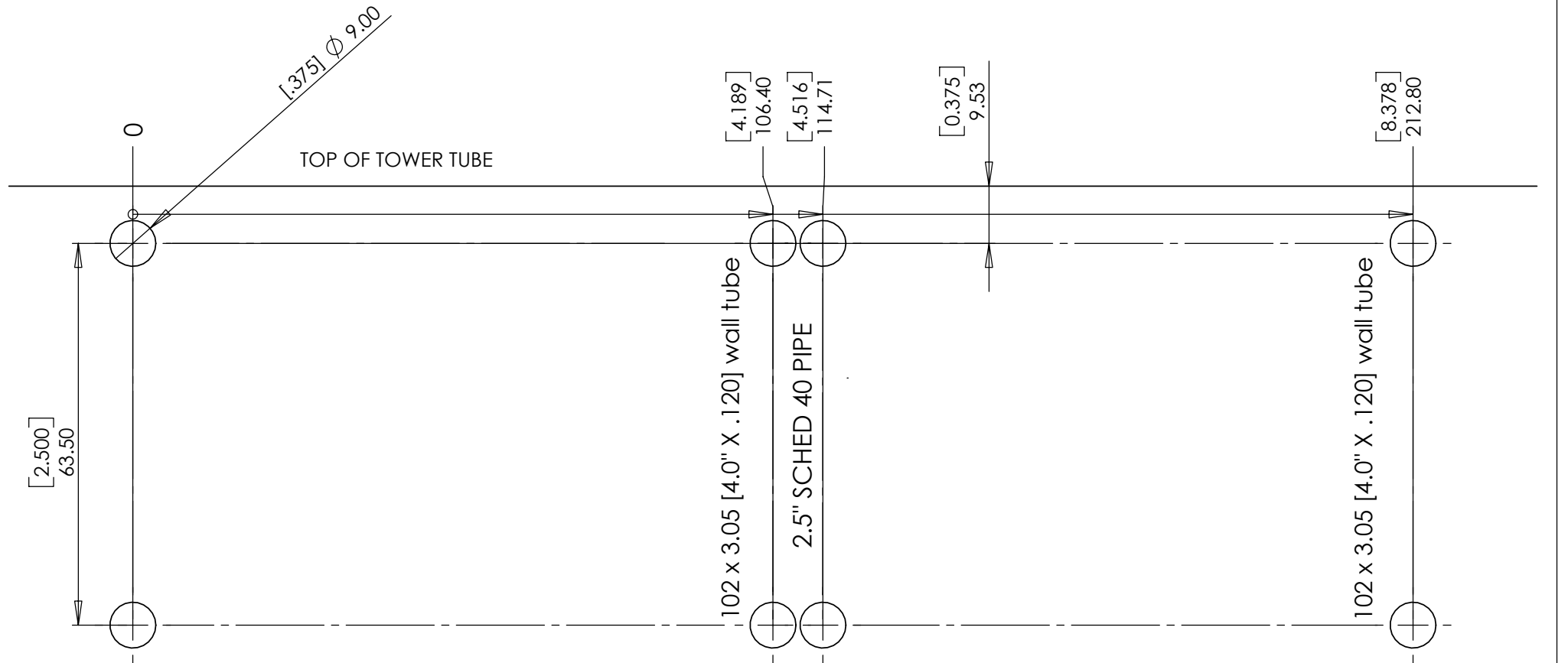

Dimensions in brackets are in inches.
This sheet should be printed full scale

- Instructions :
1. Align template to top of tower tube and tape in place.
 2. With centre punch, mark hole centres for your tower configuration.
 3. Remove template, check dimensions and drill.

Unless otherwise specified dimensions are in mm. tolerances are : distances .X ± .5 angles ± 30' .XX ± .1	CAD-generated drawing do not manually update		Southwest Windpower Flagstaff, Arizona U.S.A.
	APPROVALS	DATE	
	DRAWN D. Jones	25 sep 0	tower top drilling template CAD FILE: WP01387A tower top drilling template DWG. N° WP01387
	CHECKED		
MATERIAL -	RESP ENG J.G. Lonjaret	9 dec 3	SCALE 1 : 1 REV. A SIZE A sheet 1 of 1
FINISH --	MFG ENG		
DO NOT SCALE DRAWING		QUAL ENG	

ITEM NO.	PART OR IDENTIFYING N°	NOMENCLATURE OR DESCRIPTION	MATERIAL SPECIFICATION	QTY. REQD.	NEXT ASSY	USED ON
						H40-H80
PARTS LIST						APPLICATION